

## **A New Hybrid Cascaded Multilevel Inverter Fed Induction Motor Drive with Mitigation of Bearing Currents and Low Common Mode Voltage**

Ch.Sajan<sup>1</sup>, T. Praveen Kumar<sup>2</sup>, T.Shiva<sup>3</sup>, K.Srilatha<sup>4</sup>

<sup>1</sup>Associate Professor, Department of EEE, Jyothishmathi Institute of Technology and Science, Karimnagar, Andhra Pradesh, India.

<sup>2</sup>Associate Professor, Department of EEE, Jyothishmathi Institute of Technology and Science, Karimnagar, Andhra Pradesh, India.

<sup>3</sup>Assistant Professor, Department of EEE, Jyothishmathi Institute of Technology and Science, Karimnagar, Andhra Pradesh, India.

<sup>4</sup>M.Tech Student, Department of EEE, Jyothishmathi Institute of Technology and Science, Karimnagar, Andhra Pradesh, India.

---

**Abstract:-** This paper deals with new hybrid multilevel inverter fed induction motor drive. It focuses on the different topologies to mitigate the common mode voltages, bearing currents and their effects on the drive. In proposed topology, the total harmonic distortion (THD) is reduced with more number of steps in output voltage without using pulse width modulation techniques. The main advantage of this proposed topology is the insulation required in the motor is reduced due to low common mode voltage and mitigation of bearing currents. A new method is proposed to reduce the common mode voltage and bearing currents. This paper also focuses on the adverse effects of bearing currents in the motor drive. Simulation results obtained from Matlab/Simulink to simulate the output voltage and the parameters of the drive.

**Keywords:-** Cascaded multilevel inverter, Induction motor drive, Common mode voltage, Bearing currents mitigation techniques, Total harmonic distortion.

---

### **I. INTRODUCTION**

In recent years multilevel inverters have become a very interesting field of study in what regards their industrial application. These converters allow the synthesizing of a sinusoidal voltage waveform starting from several levels of dc voltages. However, besides that advantage there are other important advantages such as, reduced switching losses, low dv/dt's and reduced common mode voltages. Due to these characteristics several multilevel inverter topologies have been developed and studied.

Modern fast switching IGBT-inverters allow high dynamic operation of variable speed drives while leading at the same time to energy savings. However, due to the steep voltage surges, bearings may suffer from inverter-induced bearing currents. These bearing currents may destroy bearings - depending on the system within short time of operation. Recent advances in power switching devices enabled the suitability of multilevel inverters for high voltage and high power applications because they are connecting several devices in series without the need of component matching.

Cascaded H-Bridge inverters can be classified into two types based on the amplitudes of the DC sources used. They are: symmetrical multilevel inverters in which sources are of equal amplitudes and asymmetrical multilevel inverters in which sources are of different amplitudes. Compared to symmetrical multilevel inverter it can be seen that asymmetrical multilevel inverters can generate more voltage levels and higher maximum output voltage with the same number of bridges. The asymmetric multilevel inverter can produce  $N=2^{n+1}-1$ , levels (n is the number of sources and N is the number of levels in the inverter output). The main advantage of the asymmetric configuration is that it minimizes the redundant output levels.

The outputs of dc-ac converters contain common-mode voltage switched at high frequencies with voltage magnitudes that are comparable to the inverter pole voltages. High frequency switching of the common-mode voltage in the induction motor causes several issues like leakage currents through the stray capacitance between the winding and the body of the motor and create shaft voltages causing bearing currents resulting in bearing failures of the motors [3]–[6]. The effects of common-mode voltage are much more adverse in the case of medium- and high-voltage drives due to high frequency switching of common-mode voltage in the order of

few kilovolts. High  $dV/dt$  switching in common-mode voltage causes breakdown of bearing lubricant insulation and causes pitting in the bearing surfaces. This leads to quick failure of bearings.

## II. PROPOSED TOPOLOGY

The figure:1 represents the hybrid configuration of cascaded multilevel inverter for example, if the inverter has  $3^3$  different voltages (i.e., an inverter with  $s=3$  cells can generate  $3^3=27$  different voltage levels). This multilevel inverter consists of series connected cells. Each cell consists of a 4-switch H-bridge voltage source inverter. The output inverter voltage is obtained by summing the cell contributions.

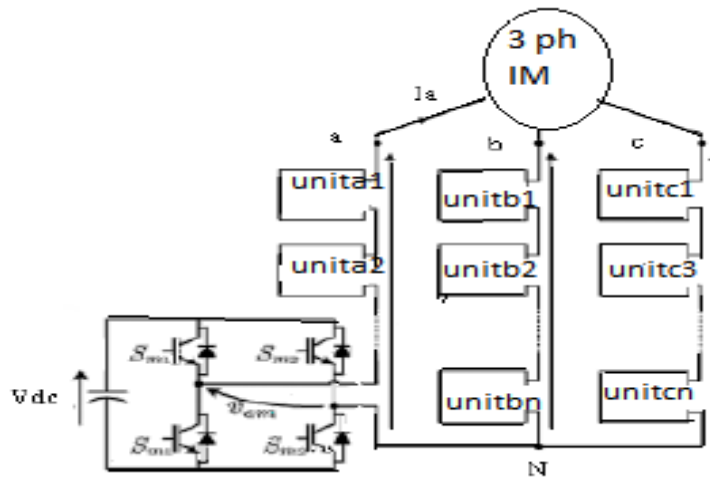

**Fig. 1 Basic new hybrid inverter scheme.**

AC motors are largely used in a wide range of modern systems, from household appliances to automated industry applications such as: ventilations systems, fans, pumps, conveyors and machine tool drives. Inverters are widely used in industrial and commercial applications due to the growing need for speed control in Drive systems. Fast switching transients and the common mode voltage, in interaction with parasitic capacitive couplings, may cause many unwanted problems in those applications. These include shaft voltage and leakage currents (or) bearing currents.

### A. Bearing Currents

The bearing currents are generated through the path between the inner face of the motor bearing and its outer face by the shaft voltage. Because there is a film of lubricant grease in the bearing, the path from the shaft to the motor frame is insulated by the grease film when the motor is running at a high speed. However, the shaft voltage can be established due to the lubricant grease dielectric ability. Its magnitude may be large enough to break down the grease depending on the drive type, the motor structure and the bearings. It has been observed that even 3V peak shaft voltage may break down the lubricant grease film and cause bearing currents. The bearing currents are generated repeatedly and become the major cause of premature failures of the motor bearings. In order to prevent premature bearing failures, several methods can be used including: mitigating common-mode voltages, short-circuiting the bearing currents and blocking the bearing currents.

## II. MITIGATION OF COMMON MODE VOLTAGE AND BEARING CURRENTS

To mitigate bearing currents, two kinds of methods are usually employed. One is to mitigate the source, the common-mode voltage on the motor shaft. Another method is to bypass the bearing currents with a slipping brush or to block the bearing currents from flowing through the motor bearings by insulating them from the motor frame. The common source of all inverter-induced bearing currents is the common mode voltage of the inverter. As the causal chain of the different bearing current phenomena is different, mitigation techniques have to be chosen according to the type of bearing current that shall be reduced or eliminated.

### A. Mitigation of Common-Mode Voltage

Mitigating common-mode voltage is the ideal method to resolve the bearing current problems because common-mode voltage is the source that can generate the bearing currents. A lot of methods such as different topologies and inverter pulse-width modulation methods have been proposed to mitigate the common-mode

voltage. These methods can effectively reduce the common-mode voltages and common-mode noise. However, the modified topologies generally increase the cost of the drives, or special arithmetical modifications give rise to some limitations in the Drive operation.

**B. Short-Circuiting Bearing Current:**

Short-circuiting bearing current is the second kind of method to cancel the adverse effects of the bearing currents. This can be realized by a shaft grounding system. It is a simple and effective method to prevent shaft voltage. However, it requires periodic maintenance. The commercial grounding system products can be applied to the drive systems with or without Adjustable Speed Drives.

**C. Blocking Bearing Current:**

Blocking bearing current is the third method to prevent the drive from bearing currents. This uses insulated motor bearings to block the bearing current. This is also a simple and effective method to protect the motor bearing. However, the modified bearings will increase their costs and sometimes effect their lifetime especially for the bigger motor bearings due to the limitation in the manufacturing techniques.

**D. Active Filter Technique:**

The active filter method applied a closed loop control system to the inverter output terminals. This system supplies very high common-mode impedance to the inverter output. It can effectively reduce the switching high  $dv/dt$  common-mode voltages on the motor terminals. However, this method needs careful design of the series common-mode choke in the inverter output, especially for high power applications. Also, it is not suitable for the low frequency common-mode voltage cancellation due to the low impedance of the ferrite choke at low frequencies. Active EMI filters based on current injection is a proper solution to cancel the common mode high frequency currents. Fig.2 shows a block diagram of an active EMI filter and common mode transducer. Proposed method is composed of an emitter follower using complementary transistors and a common mode transformer. An improved inverter output filter configuration to reduce both differential mode and common mode  $dv/dt$  at motor terminals with one filter topology is suggested in which consist of a three-phase RLC network. The filter star point is electrically connected to the dc link midpoint. A passive common mode current attenuation technique for use with PWM drives.

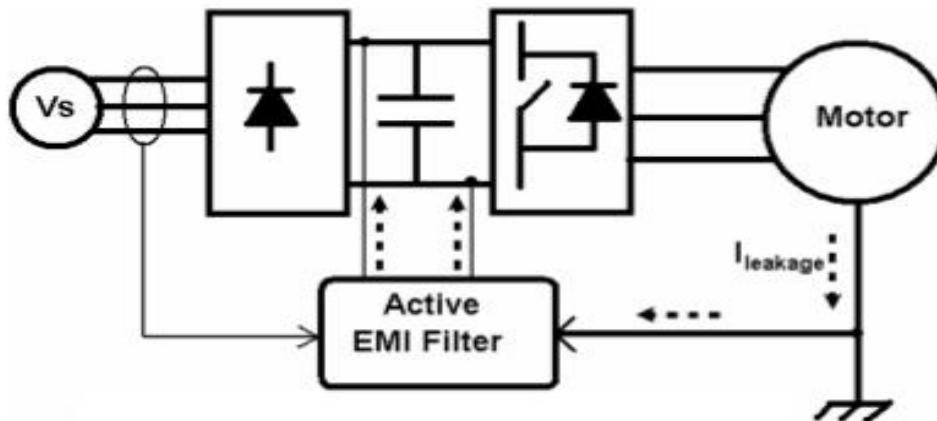

**Fig. 2 An active EMI filter**

A novel passive filter installed at inverter output terminals with an objective of eliminating the common mode and differential-mode voltage generated by an inverter simultaneously. The proposed filter consists of three inductors, three capacitors, one resistor and a common mode transformer. Introduce a new passive filter consists of a common mode transformer and a conventional RLC filter.

An active filter technique is proposed to mitigate adverse effects of an inverter fed AC drives and reduces the size of EMI filter. Proposed common mode noise canceller is composed of a push-pull type emitter follower circuit using two complementary transistors, a common mode transformer, three impedances for common mode voltage detection, and two dc voltage sources, three capacitors, inductor, and resistor. Design and analysis of a current injection type active EMI filter for switching noise of high frequency inverters. It consists of two complementary transistors as active elements and a common mode current transformer.

### III. EXPERIMENTAL RESULTS

The Matlab/Simulink model of the proposed inverter output is shown in Figure. Simulation is performed for the proposed circuit with MATLAB/SIMULINK.

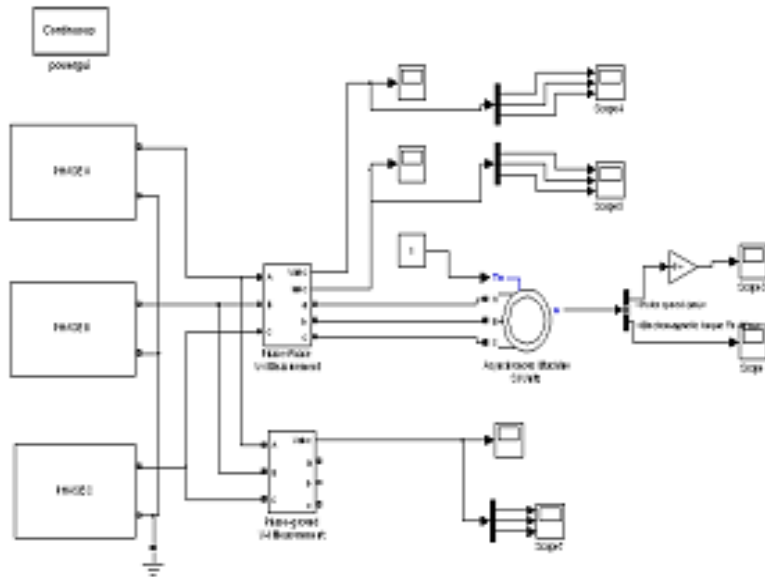

Fig. 3 Simulation diagram of proposed system

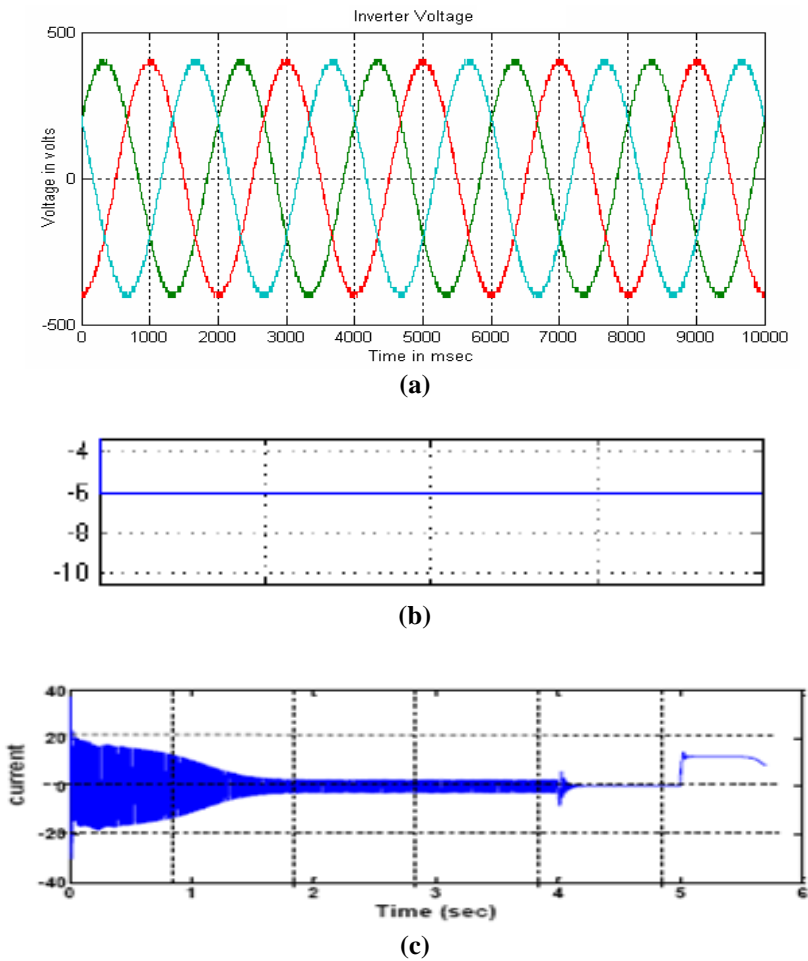
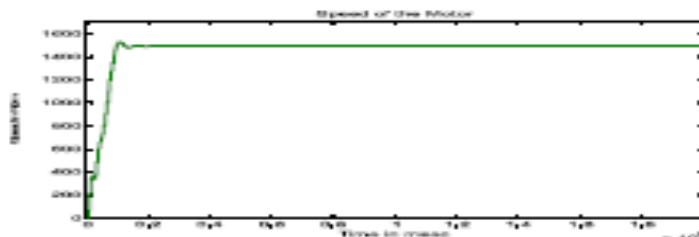

Fig. 4 (a) three phase output voltage of multilevel inverter (b) common mode voltage (c) Bearing current. It is clear that as the number of level increases, distortion reduces.



**Fig. 5 Speed of motor**

Use of one insulated bearing reduces circulating bearing currents down to at least less than 40 %, use of two insulated bearings to at least less than 20 %.

According to the present understanding, insulated bearings do not reduce the “real” bearing currents occurring inside the bearing, therefore no need to increase the insulation level beyond the required level. Hence the insulation level required for the mitigation of bearing currents in the inverter fed motor drive is reduced. This is the main advantage of the proposed topology.

#### **IV. PERSPECTIVES FOR FUTURE WORK**

The above analyses have lead to gainful shaft voltage reduction, bearing currents mitigation, and also common mode voltage reduction techniques in the motor drive systems. Opportunities for future research can be classified in the following areas.

- Optimization of motor design considering shaft voltage and bearing currents.
- Development of very high frequency converters to reduce the LC filters size.

#### **V. CONCLUSION**

In this paper different topologies were presented to mitigate the common mode voltages, shaft voltages and bearing currents, without the use of PWM techniques. The most important feature of the system is being convenient for expanding and increasing the number of output levels with very low harmonic content and the main advantage of this proposed topology is that, the reduced level of insulation level. With the use of multilevel inverters, these techniques are most widely used in various applications. The simulation results are obtained.

#### **REFERENCES**

- [1] Annette von Jouanne and Alan Wallace, “A Short Course on Adjustable Speed Drives and Utility Application Issues”, July, 2000.
- [2] A. Nabea, I. Takahashi and H. Akagi, “ A New Neutral-Point-Clamped PWM Inverter”, IEEE Transactions on Industry Applications, Vol. IA-17, No. 5, September/October 1981, pp.518-523.
- [3] S. Chen, T. A. Lipo, and D. Fitzgerald, “Source of induction motor bearing currents caused by PWM inverters,” IEEE Trans. Energy Converters., vol. 11, no. 1, pp. 25–32, Mar. 1996.
- [4] D. Macdonald and W. Gray, “PWM drive related bearing failures,” IEEE Ind. Appl. Mag., vol. 5, no. 4, pp. 41–47, Jul.–Aug. 1999.
- [5] D. Busse, J. Erdman, R. J. Kerkman, D. Schlegel, and G. Skibinski, “Bearing currents and their relationship to PWM drives,” IEEE Trans. Power Electron., vol. 12, no. 2, pp. 243–252, Mar. 1997.
- [6] M. J. Costello, “Shaft voltages and rotating machinery,” IEEE Trans. Ind. Appl., vol. 29, no. 2, pp. 419–426, Mar.–Apr. 1993.
- [7] L. A. Saunders, G. L. Skibinski, S. T. Evon, and D. L. Kempkes, “Riding the reflected wave - IGBT drive technology demands new motor and cable considerations,” in IEEE Petroleum and Chemical Industry Conference, 1996, pp. 75–84.
- [8] E. J. Bulington, S. Abney, and G. L. Skibinski, “Cable alternatives for PWM ac drive applications,” in IAS Petroleum and Chemical Industry Conference, 1999, pp. 247–259.
- [9] H. Zhang, A. Von Jouanne, S. Dai, A. Wallace, and F. Wang, “Multilevel inverter modulation schemes to eliminate common-mode voltages,” IEEE Transactions on Industry Applications, vol. 36, no. 6, pp. 1645 – 1653, 2000.
- [10] A. Gupta and A. Khambadkone, “A space vector modulation scheme to reduce common mode voltage for cascaded multilevel inverters,” IEEE Transactions on Power Electronics, vol. 22, no. 5, pp. 1672 – 1681, 2007.
- [11] D. Ruiz-Caballero, R. Ramos-Astudillo, S. Mussa, and M. Heldwein, “Symmetrical hybrid multilevel DC–AC converters with reduced number of insulated DC supplies,” IEEE Transactions on Industrial Electronics, vol. 57, no. 7, pp. 2307 –2314, jul. 2010.