

A Control Strategy in Power Management for a Grid Connected PV-FC Hybrid System

P.Harshavardhan Reddy¹, P.Suresh Babu² and G.Mahesh³

¹Assistant Professor, Dept of EEE, Annamacharya Institute of Technology & Sciences, Rajampet, Andhra Pradesh, India.

²Assistant Professor, Dept of EEE, Annamacharya Institute of Technology & Sciences, Rajampet, Andhra Pradesh, India

³PG Student, Dept of EEE, Annamacharya Institute of Technology & Sciences, Rajampet, Andhra Pradesh, India

Abstract:- This paper presents a method of maximum power point tracking, MPPT using adaptive fuzzy logic control for grid connected photovoltaic system. The system composed of photovoltaic module, boost converter and the fuzzy logic controller. The maximum power point tracking control is based on adaptive fuzzy logic to control ON/OFF time of MOSFET switch of boost converter. The complete simulation results using Simulink software for the whole system containing the PV array, boost converter, and fuzzy controller were presented. The control strategy for the boost converter and the whole system is carried out by using field programmable gate array (FPGA). The FPGA used is a Spartan 3E from Xilinx. The code of the control system is shown in VHDL language.

Index Terms- Maximum power point tracking, fuzzy logic controller ,photovoltaicarray,Pemfc(proton exchangemembrane fuel cell) model

I. INTRODUCTION

Renewable energy is currently widely used. One of these resources is solar energy. The photovoltaic (PV) array normally uses a maximum power point tracking (MPPT) technique to continuously deliver the highest power to the load when there are variations in irradiation and temperature. The disadvantage of PV energy is that the PV output power depends on weather conditions and cell temperature, making it an uncontrollable source. Furthermore, it is not available during the night. In order to overcome these inherent drawbacks, alternative sources, such as PEMFC, should be installed in the hybrid system. By changing the FC output power, the hybrid source output becomes controllable. However, PEMFC, in its turn, works only at a high efficiency within a specific power range [1], [2]. The hybrid system can either be connected to the main grid or work autonomously with respect to the grid-connected mode or islanded mode, respectively. In the grid-connected mode, the hybrid source is connected to the main grid at the point of common coupling (PCC) to deliver power to the load. When load demand changes, the power supplied by the main grid and hybrid system must be properly changed. The power delivered from the main grid and PV array as well as PEMFC must be coordinated to meet load demand. Generally the hybrid source has two control modes: 1) unit-power control (UPC) mode and feeder-flow control (FFC) mode. In the UPC mode, variations of load demand are compensated by the main grid because the hybrid source output is regulated to reference power. Therefore, the reference value of the hybrid source output must be determined. In the FFC mode, the feeder flow is regulated to a constant, the extra load demand is picked up by the hybrid source, and hence, the feeder reference power must be known. Here Fuzzy logic or fuzzy set theory is a new method of controlling the MPPT is implemented in obtaining the peak power point. It has the advantage of being robust, fast in response. Fuzzy controller operates in two basic modes coarse and fine modes. The proposed fuzzy operating strategy is to coordinate the two control modes and determine the reference values of the fuzzy control so that all constraints are satisfied. This operating strategy will minimize the number of operating mode changes, improve performance of the system operation, and enhance system stability.

II. SYSTEM DESCRIPTION

A. Structure of Grid-Connected Hybrid Power System: The system consists of a PV-FC hybrid source with the main grid connecting to loads at the PCC as shown in Fig. 1.

The photovoltaic [3], [4] and the PEMFC [5], [6] are modelled as nonlinear voltage sources. These sources are connected to dc-dc converters which are coupled at the dc side of a dc/ac inverter.

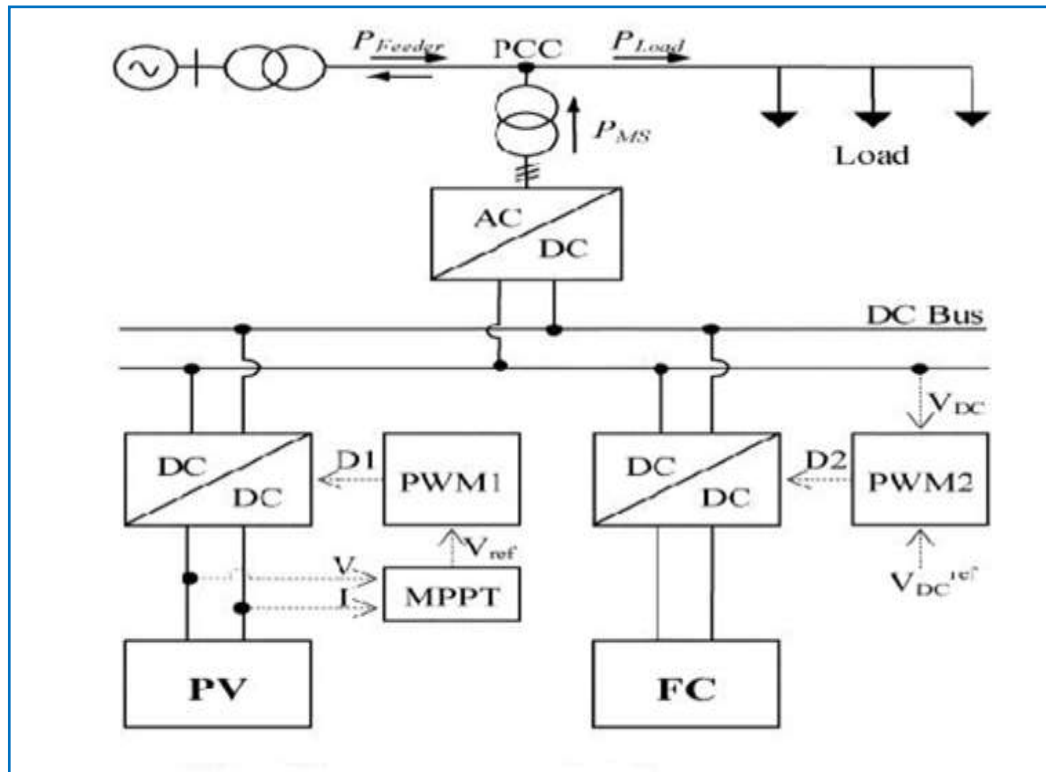

Figure 1. Grid connected PV-FC hybrid system

E_{Nerst}

The dc/dc connected to the PV array works as an MPPT controller. Many MPPT algorithms have been proposed in the literature, such as incremental conductance (INC), constant voltage (CV), and perturbation and observation (P&O). The P&O method has been widely used because of its simple feedback structure and fewer measured parameters [7]. The P&O algorithm with power feedback control [8]–[10] is shown in Fig. 2. As PV voltage and current are determined, the power is calculated. At the maximum power point, the derivative dp/dv is equal to zero. The maximum power point can be achieved

by changing the reference voltage by the amount of Δv_{ref} .

B. PV Array Model

The mathematical model [3], [4] can be expressed as

$$I = I_{ph} - I_{sat} \{ \exp[q / AKT (V + I_{RS})] - 1 \} \dots \dots \dots (1)$$

Equation (1) shows that the output characteristic of a solar cell is nonlinear and vitally affected by solar radiation, temperature, and load condition. Photocurrent I_{ph} is directly proportional to solar radiation G_a

$$I_{ph}(G_a) = I_{sc} G_a / G_{as} \dots \dots \dots (2)$$

The short-circuit current of solar cell I_{sc} depends linearly on cell temperature $I_{sc}(T) = I_{scs} [1 + \Delta I_{sc}(T - T_s)]$
 (3)

Thus, I_{ph} depends on solar irradiance and cell temperature

$$I_{ph}(G_a, T) = I_{scs} G_a / G_{as} \quad I_{scs} [1 + \Delta I_{sc}(T - T_s)] \dots \dots \dots (4)$$

I_{sat} depends on solar irradiance and cell temperature and can be mathematically expressed as follows

$$I_{sat}(G_a, T) = I_{ph}(G_a, T) / e(V_{oc}(T) / Vt(T)) - 1 \dots \dots \dots (5)$$

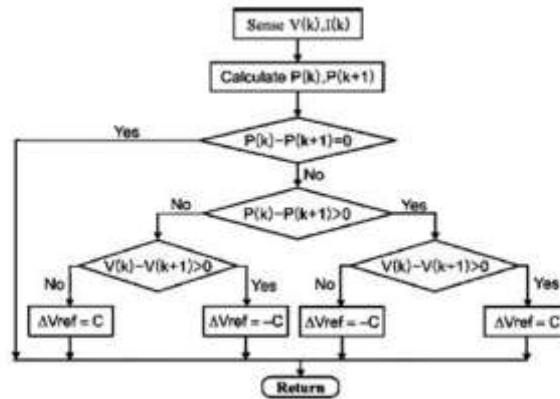

Figure 2.P & O MPPT Algorithm

C. PEMFC Model

The PEMFC steady-state feature of a PEMFC source is assessed by means of a polarization curve, which shows the nonlinear relationship between the voltage and current density. The PEMFC output voltage is as follows [5]:

$$V_{out} = E_{Nerst} - V_{act} - V_{ohm} - V_{conc} \dots \dots \dots (6)$$

Where E_{Nerst} is the “thermodynamic potential” of Nerst, which represents the reversible (or open-circuit) voltage of the fuel

cell. Activation voltage drop V_{act} is given tafel equation as

$$V_{act} = T [a + b \ln(I)]$$

where a and b are the constant terms in expressed as

$$V_{ohm} = I R_{ohm} \dots \dots \dots (7)$$

the Tafel equation (in volts per Kelvin). The overall ohmic voltage drop

$$V_{ohm} \text{ can be } \dots \dots \dots (8)$$

The ohmic resistance

R_{ohm} of PEMFC consists of the resistance of the polymer membrane and electrodes, and the resistances of the electrodes

.The concentration voltage drop V_{conc} can be expressed as

$$V_{conc} = - (RT / ZF) \ln(1 - I / I_{limit}). \dots \dots \dots (9)$$

III. FUZZY CONTROLLER

A. Fuzzy Controller

Fuzzy logic or fuzzy set theory is a new method of controlling the MPPT in obtaining the peak power point. It has the advantage of being robust, fast in response . Fuzzy controller operates in two basic modes coarse and fine modes. Input variables of fuzzy controller are $dpph / dIph$ (where Pph is PV array output power and Iph is PV array output current) and Change of it. These variables are expressed in terms of linguistic variables or labels such as PB (positive big), PS (positive small), ZE (zero), NS (negative small), NB (positive big) using basic fuzzy subset. There are three stages in this control algorithm, namely fuzzification, inference method and defuzzification. An error function (E) and a change of error (ΔE) are created during fuzzification. These variables are then compared to a set of pre-designed values during inference method, in order to determine the appropriate response. Defuzzification is for converting the fuzzy subset of control form inference back to values. The E and ΔE function is compared to the graph a & b to obtain a variable NB or ZE, then this parameter will be used to locate the respective output function (dD) from the fuzzy rule table.

ΔE E	NB	NS	ZE	PS	PB
NB	ZE	ZE	NB	NB	NB
NS	ZE	ZE	NS	NS	NS
ZE	NS	ZE	ZE	ZE	PS
PS	PS	PS	PS	ZE	ZE
PB	PB	PB	PB	ZE	ZE

Figure 3. Fuzzy rule table

This is the table of prefixed scales, which indicates the “location” of the peak power point A perturb and observe method is employed in the project due to the easy manipulation of the module and more importantly, low power loss through the process.

The IncCond method only offers little improvement over the P&O method under slowly changing atmospheric conditions. Different modules and schemes have been used to implement peak power point tracking using a microcontroller. One of those techniques which are often used is one that based on the dP/dV method. Other methods include heavy mathematical calculation and modeling. Due to the lack of resource on the PIC microcontroller and the complexity in programming, mathematical modeling method is not recommended. On the other hand, dP/dV method offers simpler design and quicker response as well as a stable solution. Therefore it is used in this work. It also offers several other useful features such as good steady state and transient response, flexibility in the control algorithm.

B. Logic Controller

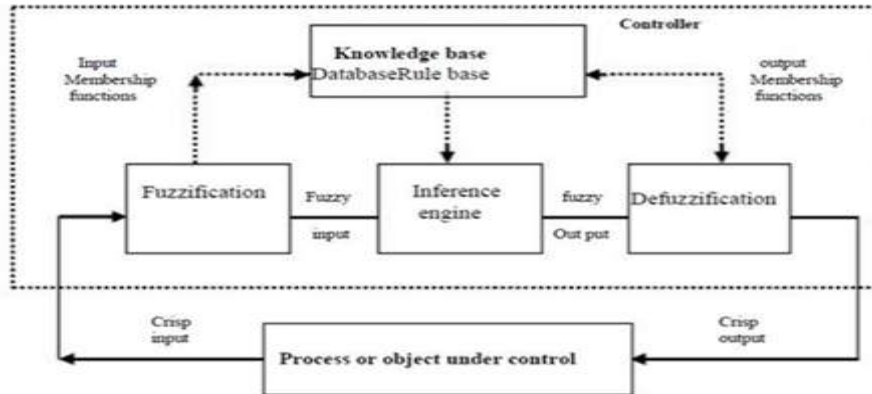

Figure 4. Fuzzy logic controller I (basic model)

C. Fuzzy Knowledge Base Controller

The fuzzy knowledge base controller is basic part of fuzzy logic control which is composed of 3 parts: Fuzzifications inference engine and defuzzification as we shown in the fig.4 and we will describe as below.

1) Fuzzifications

Membership function values are assigned to the linguistic variables, using seven fuzzy subsets: NB (negative Big), NM(Negative Medium),NS(Negative Small), ZE(Zero), PM(Positive Medium), and PB(Positive Big). The partition up to appropriate system shown in fig.4. the value of error (e) and change in error(de) are normalized by scaling factor β_e and β_{de} . In this system input scaling has designed between -1 to 1

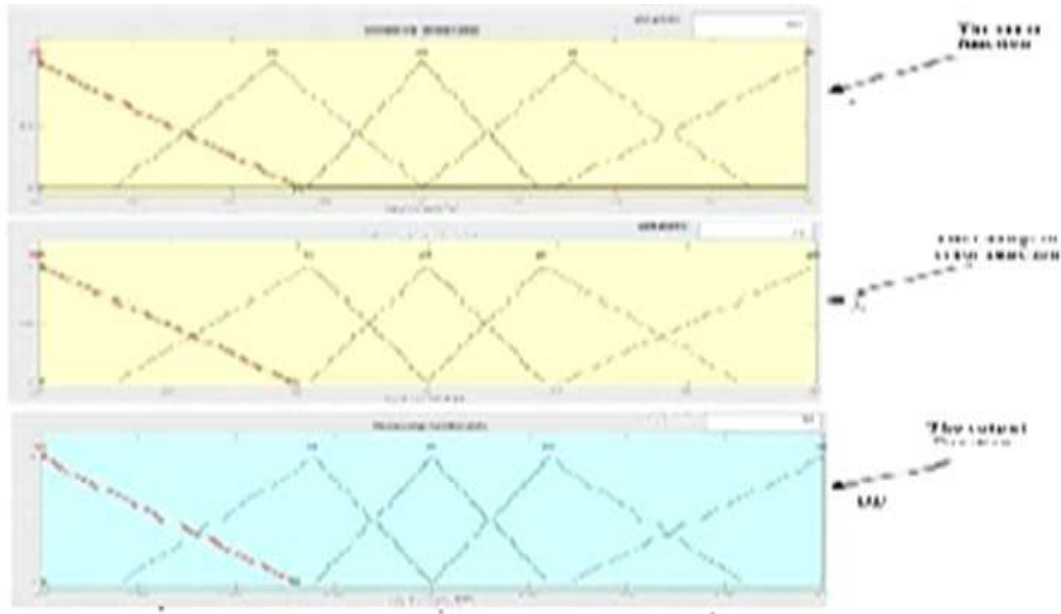

Figure 5. Fuzzy logic membership after tuning

2) Inference Method

The composition operation by which a control output can be generated. Several composition methods such as MAX-MIN and MAX-DOT have been proposed in the literature. The commonly used method is MAX-MIN (AND connection) as we used in our search. The output membership function of each rule is given by the MIN (minimum operator, MAX (maximum) operator. Table 2 shows the rule table for fuzzy logic controller.

(3) Defuzzification

As the plant usually required a nonfuzzy value of control, a defuzzification stage is needed. Defuzzification for this system is the height method. The height method is both very simple and very fast method.

Matlab based simulink model

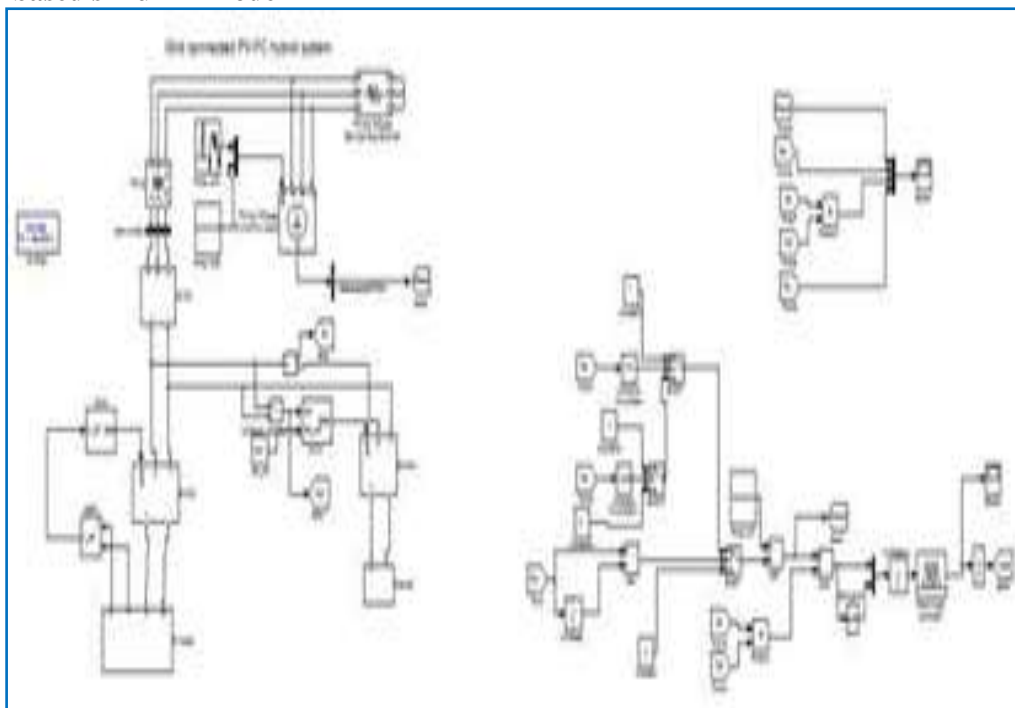

Simulation Results without hysteresis

1. a). Operation Strategy of the Hybrid System

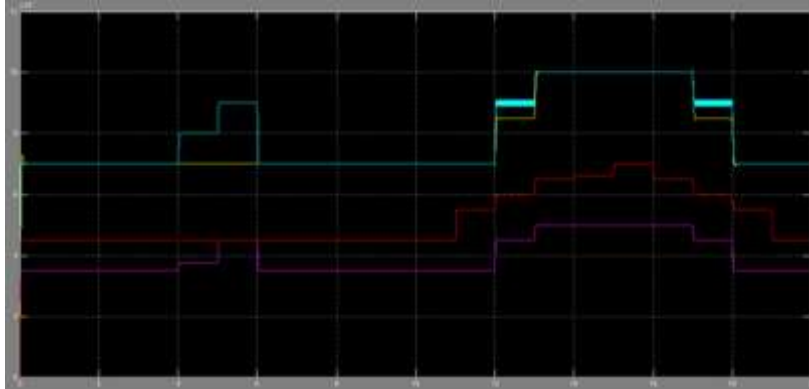

b. Operation Strategy of the Whole System

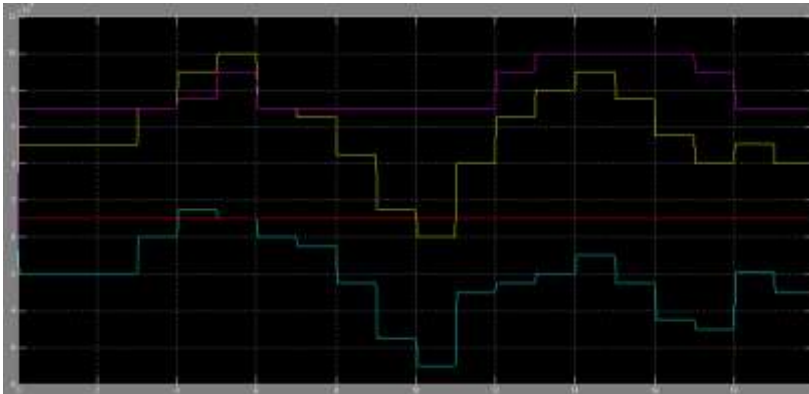

Simulation Results without hysteresis

2. a). Operation Strategy of the Hybrid System

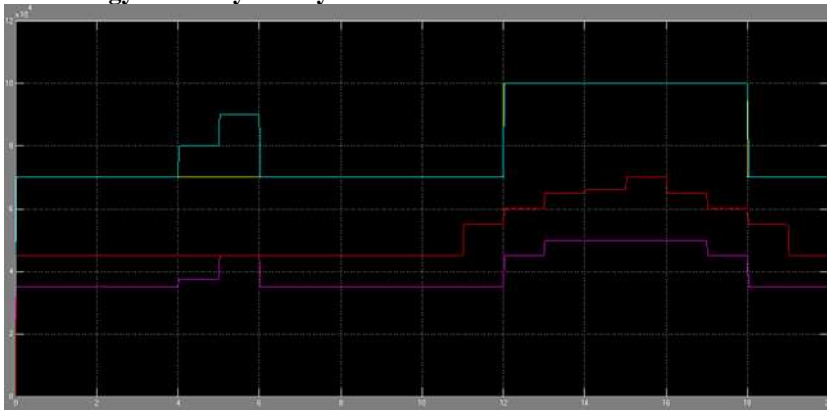

b. Operation Strategy of the Whole System

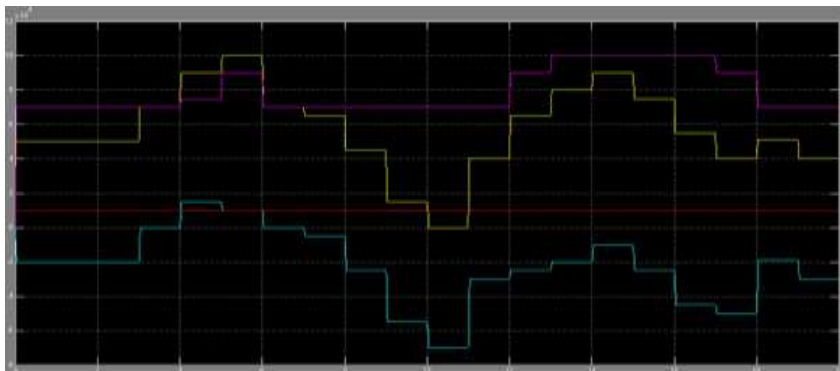

IV. CONCLUSION

The method of maximum power point tracking, MPPT using adaptive control for grid connected photovoltaic system is presented for better performance of the whole system. The MPPT control is based on adaptive fuzzy logic to control ON/Off time of MOSFET switch of boost converter. The complete simulation results are shown by using Simulink software for the whole system containing the PV array, boost converter, and fuzzy controller are also shown above.

REFERENCES

- [1]. T. Bocklisch, W. Schufft, and S. Bocklisch, "Predictive and optimizing energy management of photovoltaic fuel cell hybrid systems with short time energy storage," in Proc. 4th Eur. Conf. PV-Hybrid and Mini-grid 2008, pp. 8-15.
- [2]. J. Larminie and A. Dicks, Fuel Cell Systems Explained. New York: Wiley, 2003.
- [3]. W. Xiao, W. Dunford, and A. Capel, "A novel modeling method for cells," in Proc. IEEE 35th Annu. Power Electronics Specialists Conf.,
- [5]. D. Sera, R. Teodorescu and P. Rodriguez, "PV panel model based on datasheet values," in Proc. IEEE IntSymp Industrial Electronics, Jun. 4-7, 2007, pp. 2392-2396.
- [6]. C. Wang, M. H. Nehrir, and S. R. Shaw, "Dynamic models and model validation for PEM fuel cells using electrical circuits," IEEE Trans. Energy Convers, vol. 20, no. 2, pp. 442-451, Jun. 2005.
- [7]. C. Hua and C. Shen, "Comparative study of peak power tracking techniques for solar storage system," in Proc. 13th Annu. Applied Power Electronics Conf. Expo., Feb. 1998, vol. 2, pp. 679-685.
- [8]. A. Hajizadeh and M. A. Golkar, "Power flow control of grid-connected fuel cell distributed generation systems," J. Elect. Eng. Technol., vol. 3, no. 2, pp. 143-151, 2008.
- [9]. C. Hua and J. R. Lin, "DSP-based controller application in battery validation for PEM fuel cells using electrical circuits," IEEE Trans. Energy Convers., vol. 20, no. 2, pp. 442-451, Jun. 2005.
- [11]. C. Hua and C. Shen, "Comparative study of peak power tracking techniques for solar storage system," in Proc. 13th Annu. Applied Power Electronics Conf. Expo., Feb. 1998, vol. 2, pp. 679-685.
- [12]. A. Hajizadeh and M. A. Golkar, "Power flow control of grid-connected fuel cell distributed generation systems," J. Elect. Eng. Technol., vol. 3, no. 2, pp. 143-151, 2008.
- [13]. C. Hua and J. R. Lin, "DSP-based controller application in battery storage of photovoltaic system," in Proc. 22nd IEEE Int. Conf. Industrial Electronics, Control, and Instrumentation, Aug. 5-10, 1996, vol. 3, pp. 1750-1810.
- [14]. C. Hua, J. Lin, and C. Shen, "Implementation of a DSP-controlled photovoltaic system with peak power tracking," IEEE Trans. Ind. Electron, vol. 45, no. 1, pp. 99-107, Feb. 1998.
- [15]. E. Koutroulism and K. Kaalitzakis, "Development of a microcontroller-based, photovoltaic maximum power point tracking control system," IEEE Trans. Power Electron., vol. 16, no. 1, pp. 46-54, Jan. 2001.
- [16]. N. Mohan, T. M. Undeland, and W. P. Robbins, Power Electronics, Converters, Applications and Design, 2nd ed. New York: Wiley,