

Simulated Analysis of Resonant Frequency Converter Using Different Tank Circuits.

Aakar Mehul Sheth, Prof. Hiren Patel, Prof. Ruchit Soni

*B.E. Electrical & Electronics Engg. Electrical & Electronics Dept. Electrical & Electronics Dept.
Indus University, Ahmedabad Indus University, Ahmedabad Indus University, Ahmedabad*

Abstract:- LLC resonant frequency converter is basically a combo of series as well as parallel resonant ckt. For LCC resonant converter it is associated with a disadvantage that, though it has two resonant frequencies, the lower resonant frequency is in ZCS region [5]. For this application, we are not able to design the converter working at this resonant frequency. LLC resonant converter existed for a very long time but because of unknown characteristic of this converter it was used as a series resonant converter with basically a passive (resistive) load. Here, it was designed to operate in switching frequency higher than resonant frequency of the series resonant tank of Lr and Cr converter acts very similar to Series Resonant Converter. The benefit of LLC resonant converter is narrow switching frequency range with light load[6]. Basically, the control ckt plays a very imp. role and hence 555 Timer used here provides a perfect square wave as the control ckt provides no slew rate which makes the square wave really strong and impenetrable. The dead band circuit provides the exclusive dead band in micro seconds so as to avoid the simultaneous firing of two pairs of IGBT's where one pair switches off and the other on for a slightest period of time. Hence, the isolator ckt here is associated with each and every ckt used because it acts as a driver and an isolation to each of the IGBT is provided with one exclusive transformer supply[3]. The IGBT's are fired using the appropriate signal using the previous boards and hence at last a high frequency rectifier ckt with a filtering capacitor is used to get an exact dc waveform. The basic goal of this particular analysis is to observe the wave forms and characteristics of converters with differently positioned passive elements in the form of tank circuits. The supported simulation is done through PSIM 6.0 software tool.

Keywords:- LLC(Inductor Inductor Capacitor), ZCS(Zero Current Switching), Resonance, variable frequency converter, Control Circuit, Supply Circuit, Dead band Circuit, Driver Circuit, IGBT circuit board, High frequency rectifier and filter, IR1(Load Current), VR1(Load Voltage).

I. INTRODUCTION

This particular converter plays an important role in the rectification of ac supply where firstly, an ac waveform will be rectified through a converter while the rectified waveform that is obtained will be supplied into the Inverter circuit containing IGBT as switch. There are two similar pairs of IGBT's which allows the inversion process, but two entirely different cycles of operation are carried in this process. This particular entire operation is followed by a LLC tank circuit, where resonance plays its part and again through a H.F. Transformer the pulse is given to the H.F. Rectifier for obtaining a perfect o/p. Here, the design of the converter is basically with respect to variable frequency up to 5kHz and the design is basically for a 500W converter with highest efficiency.

Block Diagram

Fig. 1 shows the block diagram associated with the exact model. It's description starts with the single phase bridge rectifier, as is fed from the single phase sinusoidal supply and it will be converted into uncontrolled DC supply. This particular dc supply is then fed into the Full Bridge Inverter circuit which goes into the LLC tank circuit and hence the sinusoidal wave gets modified through the given tank circuit characteristics. This wave is then stepped down with the help of the H.F. Transformer and in order to obtain a pulsating d.c. We put it through the H.f. Rectifier. But, in order to get a unidirectional d.c. Pulse we use a H.F. Capacitor filter through which we get the exact and desired supply.

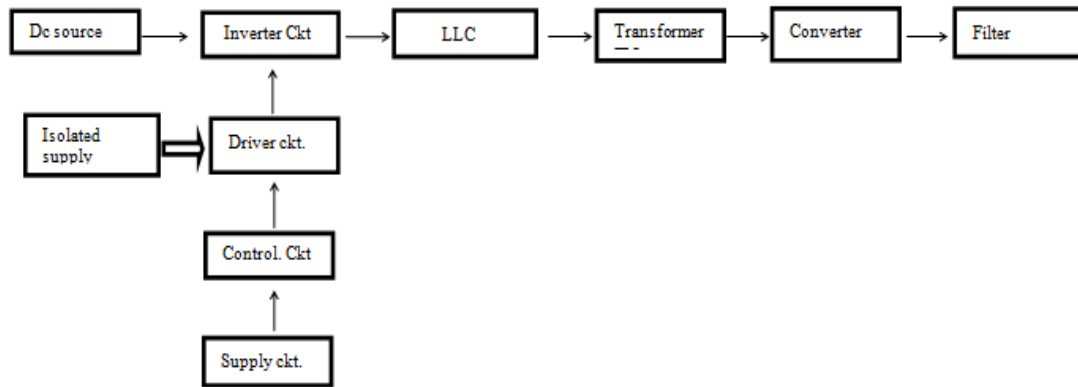

Fig: 1 Block Diagram of Resonant Frequency Converter Using Tank Circuit [5]

II. RESONANT CONVERTER DESIGN.

A. Design Configurations:

The design criteria of 500W resonant frequency converter is described in this section. The exact value of output voltages and currents are stated below considering the Indian Standard Electricity Rules.

For a 500w (dc-dc) converter [1]:

Here, we want o/p voltage=100V, o/p current=5A

Hence; here we have chosen a 230V dc source.

Now; taking in consideration regulation of +/-10% according to standard Indian electricity rules.

Vmin=186V dc, Vmax=227V dc

Hence; considering a dc voltage source of 200V. By this, N_2/N_1 =Turns of step down transformer =2:1ANS(1)

Here, we have taken nominal values of $m=6.3$ & $Q_{max}=0.4$. Now, having to design the ckt.

Considering calculation of resonant induction & capacitor.

$Q_{max}=\sqrt{L_r/C_r}/R_{ac}$ (1) $f_r=1/2*3.14*\sqrt{L_r C_r}$ (2)

Solving both these equation we get the value of $L_r=70\mu H$, $L_m=600\mu H$, $C_r=1000\mu F$ANS(2)

Where; $L_m=L_r+L_m/L_r$ (3)

Here; $f_s=5kHz$, $f_r=600Hz$ANS(3)

Hence, varying the value of frequency from 5 kHz to 600 Hz we get following above waveform [1]

III. SIMULATION RESULTS:

The given figures show the exact simulation results from step to step conversion. Simulation is carried out using PSIM 6.0 Software tool. Each simulation is represented with its corresponding waveform.. Entire simulation can be described in steps below.

Specifications:

Input voltage-230V \pm 10%, 50 Hz,

Output voltage- 100V

Output current- 5A

Output Power- 500W

Switching Frequency- 600Hz to 5kHz

$L_r=70\mu H$, $L_m=600\mu H$, $C_r=1000\mu F$

A. AC-DC Rectifier Simulation With Its Waveforms.

This circuit mainly consists of 4 diodes and hence forms an uncontrollable rectifier circuits whereby the load current and the load voltage is depicted through the wave forms. Here by the source of ac is 230 V ac which is then converted into pulsating dc of approximately 200 V and 2 A.

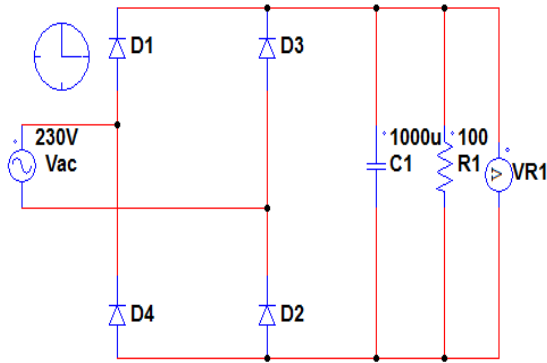

Fig: 2(a) AC-DC Rectifier

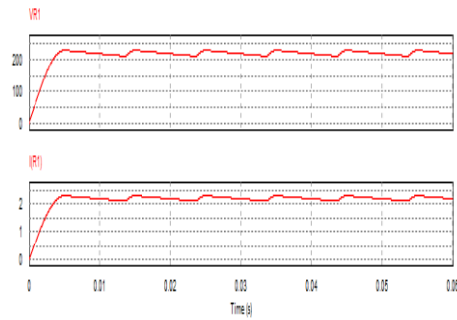

Fig: 2(b)Waveform: VR1-Up to 200V & IR1- Up to 2A

2A

Pulsating voltage and current as filter not inculcated.

B. AC-DC Rectifier Simulation With Added Filter and Its Simulation.

This circuit mainly consists of 4 diodes and hence forms an uncontrollable rectifier circuits whereby the load current and the load voltage is depicted through the wave forms. Here by the source of ac is 230 V ac which is then converted into pulsating dc of approximately 200 V and 2 A. The only difference of the above and the below circuit is the addition of a filter in the form of an inductor to obtain unidirectional dc.

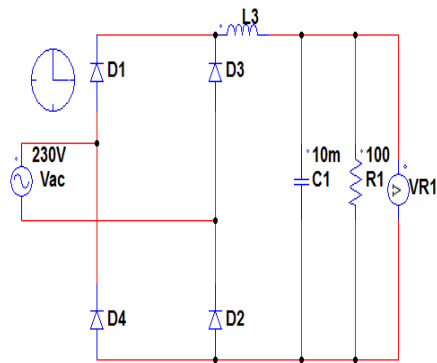

Fig: 3(a) AC-DC Filter Ckt.

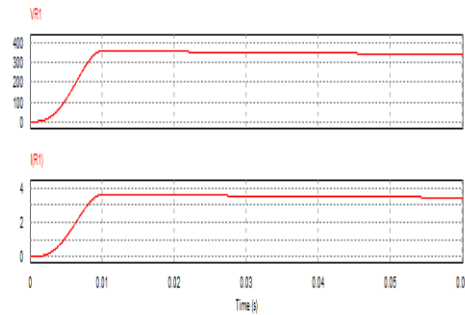

Fig: 3(b) Waveform: VR1 & IR1. Filter is inculcated.

C. Dead Band Circuit Implementation Using NAND Gate.

The basic circuit associated with the dead time generator is shown below which mainly consists of a combination of resistor and capacitor along with a Gate [3]

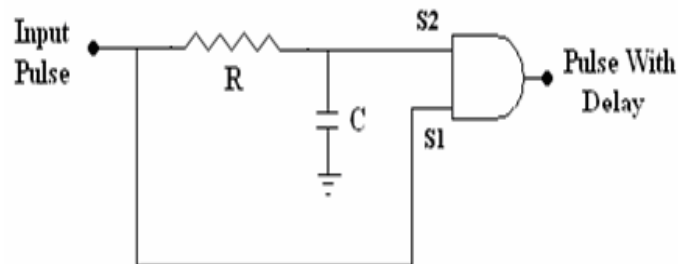

Fig: 4(a) Dead Time Generator.

Input side square pulse S1 is applied. During ON time of input pulse Capacitor C will charge through resistor R. In OFF condition the Capacitor will discharge through resistor R. So discharging signal will reduce. By AND Gate signal S1 and S2, delay in rise time will generate. Here, time delay calculations are as follows:
 Time Delay = $R * C = 5K * 470P = 2 \mu$ Sec.

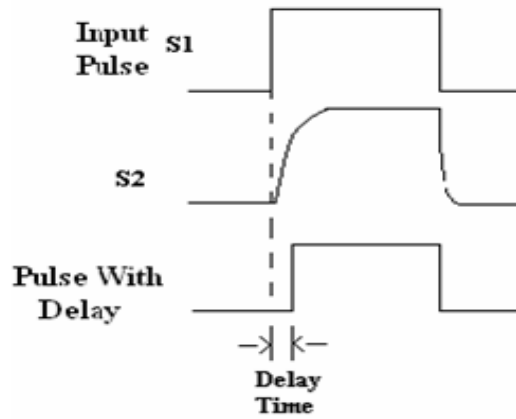

Fig: 4(b) Waveforms Of Dead Time Generator.

Through the below simulation we prove the above given fact of obtaining a dead band of 2 micro seconds by making the use of NAND gate, resistors and capacitors.

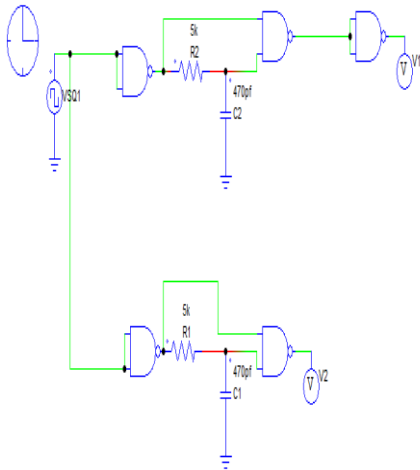

Fig: 4(c) Dead Band Circuit

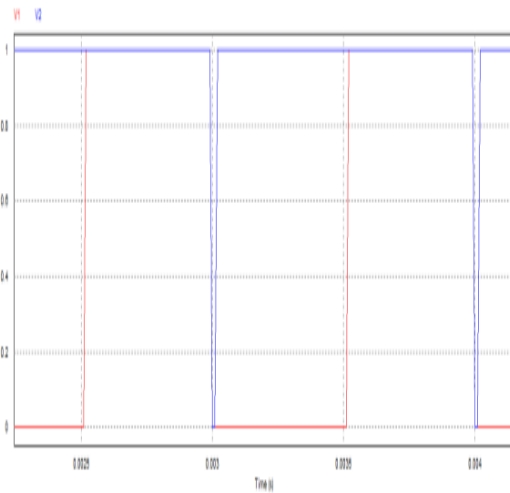

Fig: 4(d) Wave forms: V1 & V2. Rising Edge & Falling Edge.

D. Full Bridge Resonant Lag Inverter

This simulation consists of the 2nd stage in the converter whereby the unidirectional dc is converted into further ac with the help of tank circuit i.e. Vs lagging behind the Vp and also the current lags wrt the voltage as we can see in the 2nd waveform. Here, we see that the capacitor has a particular position due to which the particular phenomenon is taking place. The waveform of simulation indicates the following phenomenon.

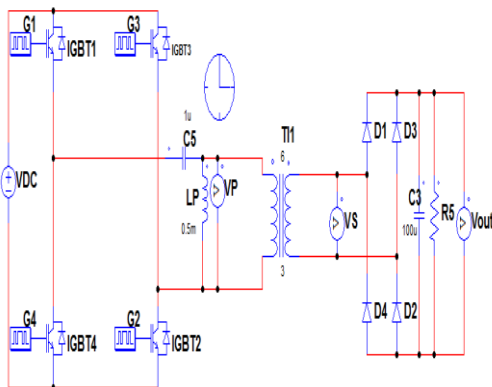

Fig: 5(a) Full bridge Lag Inverter

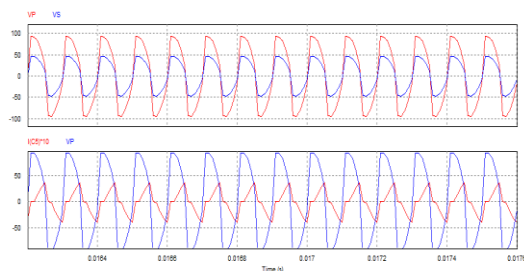

Fig: 5(b) Waveforms: Vs & Vp.

E. Full Bridge Resonant Lead Converter.

This simulation consists of the 2nd stage in the converter whereby the unidirectional dc is converted into further ac with the help of tank circuit i.e. the current leads wrt the voltage as we can see in the 2nd waveform. Here, we see that the capacitor has a particular position due to which the particular phenomenon is taking place. The waveform of simulation indicates the following phenomenon.

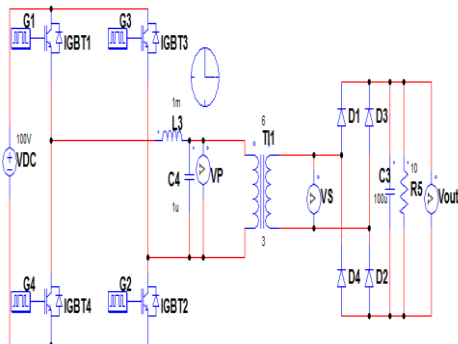

Fig:6(a) Full bridge resonance inverter(lead)

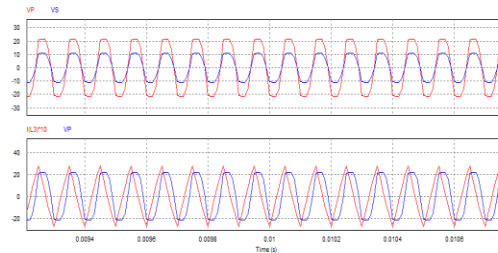

Fig: 6(b) Waveform-Vs&Vp Along With Ic and Vp.

F. Regular Dc-Dc Converter Design With 5KHz Frequency

This converter basically displays the last stage of innovation where we see the use of LLC tank circuit and after the implementation of leading and lagging inverters we make this particular simulation for a broader prospect where we see that a filter is also used on the secondary side of the transformer to obtain a voltage of about 200V and 5 A current.

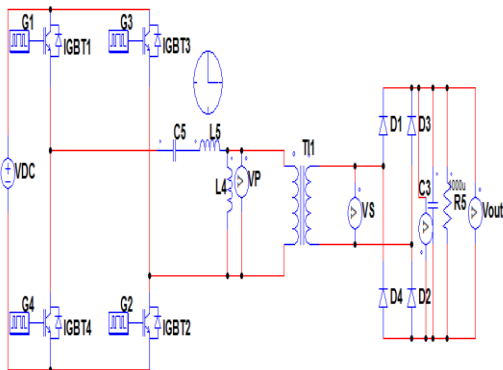
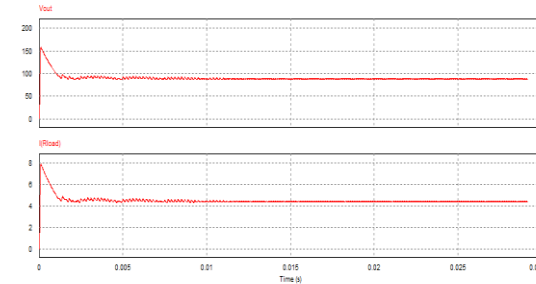

Fig: 2(e) Basic Converter design with 5kHz freq. Wave forms: Vout & Iout, where Vout=app 200V , Iout=5A



Here, as per the given simulations and their waveforms we can see the step by step formation of the basic converter which basically starts from the full bridge rectifier and hence according to the format it continues on. Here, we basically get a 500 W converter with Voltage values of approximately 100V and current value reaching to about 5A. The basic problem faced in constructing and simulating this converter is the calculation values of tank circuit. The frequency factor also played an important role as we have designed a variable frequency converter.

IV. CONCLUSION

The background regarding various aspects of Resonant frequency converter was studied. The carrier based project was simulated on PSIM. Hardware ckt contains of two types of main ckt i.e. Control Ckt & Supply Ckt. The control ckt consists of 555 timer & IGBT s work as switching device. Hence a better efficient system has been developed .The final output is a prototype model & simulation models are as similar as possible. Basically, a regulation of +/- 10% is achieved whereby we also achieve a variable frequency from 600Hz to 5kHz whereby we can vary the speed of an adjusted load in the form of a motor by varying the given frequency. Hence, induction furnace and variable speed motors can be adjusted as a load to this system as an application.

ACKNOWLEDGMENT

A Research Paper is one the important factors for an engineering student as well as a Professor. Teaching students is a hard enough job, but it is even harder to inspire them to teach themselves. We take this opportunity to express our sincere thanks to our head of the department Prof. S P Yadav and our college staff for sparing their valuable time for us. We would express our heartfelt thanks to all the honorable persons for encouraging us. We also thank the electrical & electronics department staff as well as the lab assistance for their kind co-operation.

REFERENCE:

- [1]. Infineon Notes Of LLC Resonant Converter Topologies.
- [2]. Resonant Mode Converter Topologies. (TEXAS INSTRUMENTS)
- [3]. I.C.A By Gaekwad
- [4]. Resonant Frequency Converters Vol. 1,2,3
- [5]. Fundamental Electronics by P.S Bhimbra
- [6]. Power Electronics by Muhammad Rashid.
- [7]. J.Takahashi, H.Takano "A state-of-the-art 50kw-10khz soft-switching assisted PWM dc-dc converter for x-ray power generator", IEEE Power Convergence Conference vol. 3, pp. 165–170. April 1993.
- [8]. W. Lu, X.Wu, L. Zhengyu, Z. Qian, "Wide input voltage isolated dc-dc converter with interleaving control", power electronics motion control conference, pp.94-99, Aug.2006.
- [9]. L.Umanand, S.R.Bhat, "Design of magnetic components for switched mode power converters", Wiley Eastern Limited", 2nd Edison, India, pp.1–3,1992
- [10]. A. I. Pressman, "Switching power supply design."The McGraw-Hill Companies, 2nd Edison, India, pp. 37–104,1999