

## PAPR Reduction using combined LDPC and DCT with Companding Transform in OFDM System

K.Muralibabu<sup>1</sup>, Dr. K.Rama Naidu<sup>2</sup>, Dr. S.Padmanabhan<sup>3</sup>, G.Praveen kumar<sup>4</sup>

<sup>1</sup>Research Scholar, JNTU, Anantapur

<sup>2</sup>Professor, JNTUA College of Engineering, Pulivendula, Andhra Pradesh, India

<sup>3</sup>Professor, St. John's College of Engg & Tech, TN, India.

<sup>4</sup>Lecturer, Global institute of Engg & Tech, TN, India.

---

**Abstract**— Communication methods are increasing day by day. Orthogonal frequency division multiplexing (OFDM) systems is one of the most recent emerging trends in wireless communication. However, the major drawback of OFDM is the high Peak-to-Average Power (PAPR) which results in the Bit Error Rate (BER) performance degradation. A number of approaches have been proposed to deal with the PAPR problem. In this paper, PAPR reduction in OFDM systems is based on combining Low-Density Parity Check (LDPC) codes and Discrete Cosine Transform (DCT) with companding technique. Thus the proposed scheme involves three steps: First, applying LDPC codes on the original signal for decreasing both the PAPR and BER. Second, the DCT is applied on the LDPC output. Finally, the proposed scheme utilizes the companding technique to further reduce the PAPR of the OFDM system.

**Keywords**—OFDM, PAPR, Discrete Cosine Transform, LDPC codes.

---

### I. INTRODUCTION

OFDM system has been used for high speed digital communications such as DAB (Digital Audio Broadcasting), DVB (Digital Video Broadcasting), digital HDTV (High-Definition Television) and ADSL (Asymmetric Digital Subscriber Line) due to robustness to the narrowband interference and severe multi-path fading. Most of the radio systems employs high power amplifiers (HPAs) in the transmitter for sufficient transmit power. To achieve the maximum output power efficiency, the HPA is usually operated on or near the saturation region. The nonlinear characteristics of HPA is very sensitive to variation in signal amplitudes. Unfortunately, the variation of OFDM signal amplitude is very wide with large peak-to-average power ratio. Large PAPR also demands Analog-to-Digital Converters (ADC's) with large dynamic range [1, 8].

Recently, researchers have proposed various approaches to reduce the PAPR including clipping, companding [1], selected mapping (SLM) [7], non linear companding transforms [3,8], Hadamard transforms [2] and DCT [4]. A large PAPR corresponds to a high probability of the OFDM signal being clipped when passing through a power amplifier at the end of the transmitter. Clipping reduces the signal power but degrading bit error rate (BER) performance and causing non linear phenomena such as spectral spreading. Spectral spread causes degradation of spectral efficiency.

The Hadamard transforms [2] reduces the autocorrelation of input sequence to reduce the peak to average power, when compared to the original OFDM system. We proposed an efficient PAPR reducing technique based on combined LDPC and DCT with companding. The forward error correction code LDPC encoder is placed next to data source. The encoded data in the OFDM signal are modulated by an IFFT (Inverse Fast Fourier Transform) after being processed with the DCT, which can reduce the PAPR, then companding is applied further to reduce the PAPR of the OFDM signal.

The paper is organized as follows. Section 2 presents the PAPR problem in OFDM system. LDPC and DCT are introduced in section 3 and section 4. In section 5, the companding technique is proposed. Proposed scheme discussed in section 6. Measurement and simulation results are given in section 7, followed by the conclusions and future works in section 8.

### II. PAPR IN OFDM SYSTEMS

In generic OFDM systems, the whole system bandwidth is divided into many orthogonal sub-channels with narrow bandwidth and the data symbols typically modulated by PSK (Phase Shift Keying) or QAM (Quadrature Amplitude Modulation) are transmitted independently on the sub carriers. An OFDM signal consists of N symbols  $X = \{X_k, k = 0, 1, 2, \dots, N-1\}$  and each symbol is modulated by one of a set of sub carriers  $\{f_k, k = 0, 1, 2, \dots, N-1\}$ , where N is the number of sub carriers. The 'N' sub carriers are chosen to be orthogonal, that is  $f_k = k\Delta f$ , where  $\Delta f = \frac{1}{NT}$  (Hz) and T is the original symbol period. Therefore, the complex envelope of the transmitted OFDM signals can be written as,

$$x(t) = \frac{1}{\sqrt{N}} \sum_{k=0}^{N-1} X_k e^{j2\pi f_k t}, \quad 0 \leq t \leq NT \quad (1)$$

The PAPR of OFDM signals  $x(t)$  is defined as the ratio between the maximum instantaneous power and its average power during its OFDM symbol.

$$PAPR[x(t)] = \frac{\max_{0 \leq t \leq NT} [|x(t)|^2]}{P_{avg}} \quad (2)$$

where,  $P_{avg}$  is the average power of  $x(t)$  and it can be computed in the frequency domain. Because Inverse Fast Fourier Transform (IFFT) is a (scaled) unitary transformation.

$$P_{avg} = \frac{1}{NT} \int_0^{NT} |x(t)|^2 dt \quad (3)$$

In equation (3), the PAPR reduction of OFDM signals is mainly achieved by minimizing the maximum instantaneous signal power  $\max_{0 \leq t \leq NT} |x(t)|^2$ . For better approximation, the continuous time OFDM signal  $x(t)$  samples over sampled by a factor of  $L$  at frequency  $f_s = L/T$ , where  $L$  is the over sampling factor. This is extended from original signal  $x(t)$  by using the zero-padding scheme .i.e., by inserting  $(L-1)N$  zeros in the middle of the  $x(t)$ . The over sample IFFT output with operation length  $NL$  can be expressed as

$$x(n) = \frac{1}{\sqrt{N}} \sum_{k=0}^{N-1} X(k) e^{j\frac{2\pi k n}{LN}} \quad 0 \leq n \leq LN - 1 \quad (4)$$

The PAPR computed from the ‘ $L$ ’ times over sampled time domain OFDM signal sample can be defined as

$$PAPR\{x[n]\} = \frac{\max_{0 \leq n \leq NL} [|x(n)|^2]}{E[|x(n)|^2]} \quad (5)$$

where,  $E[.]$  – denotes the expectation operator and it will be taken over all OFDM symbols.

### III. LDPC ENCODER

LDPC codes are a class of linear block codes. The name comes from the characteristics of their parity –check matrix which contains only a few 1’s in comparison to the amount of 0’s. Basically there are two different possibilities to represent LDPC codes. They can be described via matrices (or) graphical representation. The following parity check matrix with dimension  $n \times m$  for a (8, 4) code.  $w_r$  for number of 1’s in each row (row weight) and  $w_c$  for the columns (column weight). LDPC codes are classified into two groups, regular LDPC codes and irregular LDPC codes. Regular LDPC codes have a uniform column and row weight, and irregular LDPC codes have a non-uniform column and row weight. For a matrix to be called low-density the two conditions  $w_c \ll n$  &  $w_r \ll m$  must be satisfied.

$$X = \begin{bmatrix} 0 & 1 & 0 & 1 & 1 & 0 & 0 & 1 \\ 1 & 1 & 1 & 0 & 0 & 1 & 0 & 0 \\ 0 & 0 & 1 & 0 & 0 & 1 & 1 & 1 \\ 1 & 0 & 0 & 1 & 1 & 0 & 1 & 0 \end{bmatrix}$$

### IV. DISCRETE COSINE TRANSFORM

The peak value of the auto correlation is the average power of input sequence. To reduce the PAPR in an OFDM signal, DCT is applied to reduce the autocorrelation of the input sequence before the IFFT operation. The one-dimensional DCT with length  $N$  is expressed as,

$$X[k] = \alpha(t) \sum_{n=0}^{N-1} x(n) \cos\left\{\frac{(2n+1)\pi k}{2N}\right\} \quad 0 \leq k \leq N - 1 \quad (6)$$

$$\alpha(k) = \sqrt{\frac{1}{N}} \quad \text{if } k = 0$$

$$\alpha(k) = \sqrt{\frac{2}{N}} \quad \text{if } k \neq 0$$

The IDCT is expressed as

$$x[n] = \alpha(t) \sum_{k=0}^{N-1} X[k] \cos\left[\frac{(2n+1)\pi k}{2N}\right], 0 \leq n \leq N-1 \quad (7)$$

Equation (6) can be expressed in matrix form

$$X_n = C_n x$$

Both  $X_n$  and  $x$  are both vectors of dimensions  $N \times 1$ .  $C_n$  is a DCT matrix of dimension  $N \times N$ . The relation between autocorrelation and PAPR can be given as [6]

$$\rho_k = \sum_{n=1}^{N-k} x(n+k)x^*(n) \quad \text{for, } k = 0, 1, \dots, N-1 \quad (8)$$

The maximum PAPR is

$$PAPR \leq 1 + \frac{2}{N} \sum_{k=0}^{N-1} |\rho_k| \quad (9)$$

## V. COMPANDING TECHNIQUES

The samples of OFDM signal  $x(n)$  are companded before it is converted into analog waveforms. A compression is used at the transmitter end after the IFFT block and a expansion is used at the receiver end before the FFT block. The companded signal  $S(n)$  can be expressed as

$$S(n) = C\{x(n)\} = \frac{v x(n)}{\ln(1+u)|x(n)|} \ln\left(1 + \frac{u}{v}|x(n)|\right) \quad (10)$$

Where,  $V$  is the average amplitude of the signal,  $u$  is the companding parameter,  $x(n)$  is the input of the compressor and  $S(n)$  is the output of the compressor. The companding transform should satisfy the following two conditions:

$$E(|S(n)|^2) \approx E(|x(n)|^2) \quad (11)$$

$$|S(n)| \geq |x(n)| \quad \text{for } |x(n)| \leq v \quad (12)$$

$$|S(n)| \leq |x(n)| \quad \text{for } |x(n)| \geq v \quad (13)$$

The expanded signal at the receiver

$$Y(n) = C^{-1}\{r(n)\} = \frac{v r(n)}{u|r(n)|} \left\{ \exp\left[\frac{|r(n)| \ln(1+u)}{v}\right] - 1 \right\} \quad (14)$$

## V. PROPOSED SCHEME

To reduce the PAPR of an OFDM signal, the proposed techniques contain combined LDPC and DCT with Companding transform. The input data stream is first processed by LDPC, then with DCT. Next the signal processed by IFFT and companding transform (see fig. 1)

The steps followed in the proposed scheme are described as below:

Step 1: Input sequence apply to LDPC encoder to generate parity - check matrix  $X$

Step 2: Sequence  $X$  is transformed using the DCT matrix .i.e,  $Y = \text{DCT}(X)$

Step 3: Sequence  $Y$  is applied to IFFT .i.e.,  $y = [y(1), y(2), y(3), \dots, y(N)]^T$

Step 4: A companding transform is then applied to  $y$ . i.e.,  $S(n)=C\{y(n)\}$

Step 5: An inverse companding transform is applied to the received signal  $r(n)$ . i.e.,  $\hat{y}(n)=C^{-1}\{r(n)\}$

Step 6: A FFT transform is applied to the signal  $\hat{y}$ . i.e.,  $\hat{Y}=FFT\left[\hat{y}(n)\right]$

$$\text{where } \hat{y} = \left[ \hat{y}(1), \hat{y}(2), \dots, \hat{y}(N) \right]^T$$

Step 7: An IDCT transforms applied to the signal  $\hat{Y}$  i.e.,  $\hat{X}=IDCT(\hat{Y})$

Step 8: LDPC decoding is applied to  $\hat{X}$

Step 9: The sequence  $\hat{X}$  demapped to form output bit stream.

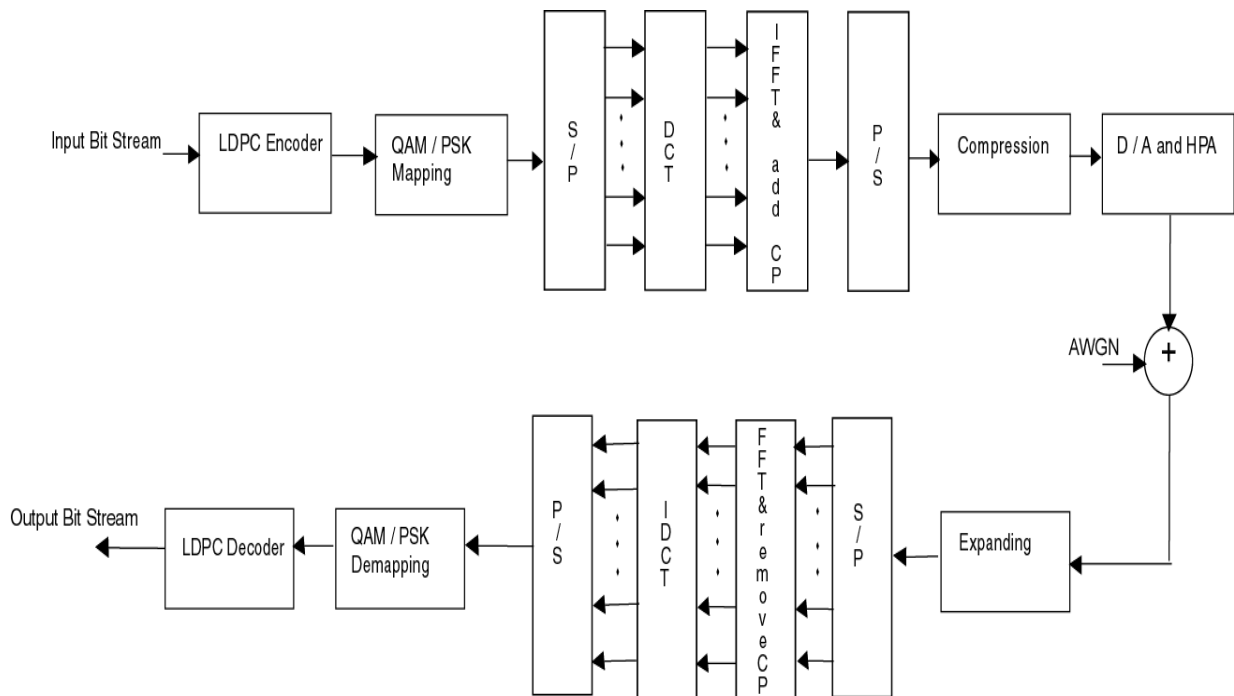

**Fig 1 Block diagram of OFDM system with LDPC, DCT and Companding**

## VI. CCDF PERFORMANCE AND SIMULATION RESULTS

Complementary Cumulative Distribution Function (CCDF=1-CDF) are obtained by checking how often PAPR exceeds the threshold values. The threshold value is chosen between the minimum and maximum value of PAPR. The number of thresholds can be based on the threshold factor. If the threshold factor is 2, then the values of threshold are,

$$[\max(\text{PAPR}) - \min(\text{PAPR})] / 2 \text{ and } [\max(\text{PAPR}) + \min(\text{PAPR})] / 2$$

$$\text{CCDF} = P(\text{PAPR} > \text{threshold}) = 1 - P(\text{PAPR} < \text{threshold}) \quad (15)$$

Fig.2 shows that the reduction of PAPR using Companding only is better than the PAPR reduction using DCT only and directly on the original signal.

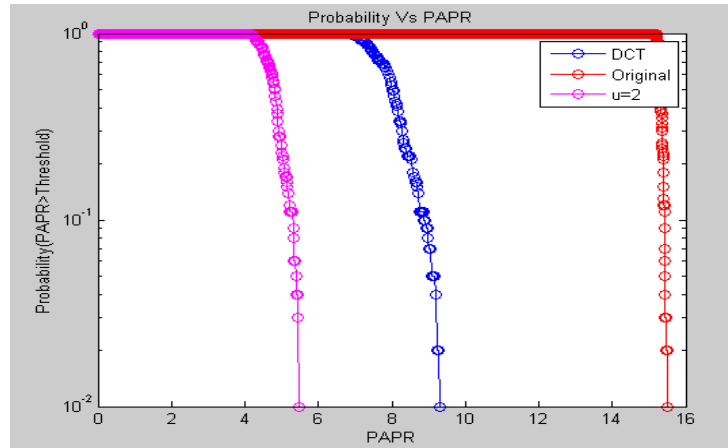

Fig 2 Comparisons of CCDF among DCT and companding

Fig.3 shows the CCDF among various transforms (DCT, Haar) with the companding parameter as  $u=2, 3,$  and  $5$ . From this it is clear that when the companding parameter ‘ $u$ ’ value increases, then the PAPR reduction will be better. Also, the PAPR reduction with DCT is better than the Haar Transform.

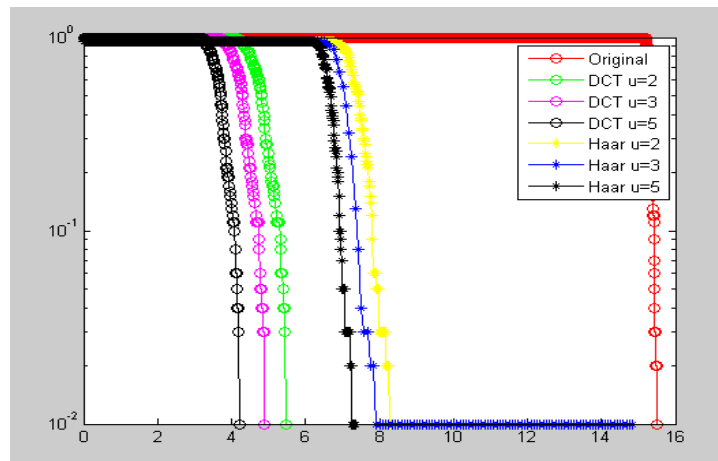

Fig 3 Comparisons of CCDF in different transforms with companding

Fig.4 shows the reduction of PAPR among Original signal with Companding, DCT on the original signal with Companding, and LDPC, DCT, and Companding on the original signal. It clearly tells you that the performance of PAPR reduction with the LDPC + DCT + Companding is very well better than the other combinations.

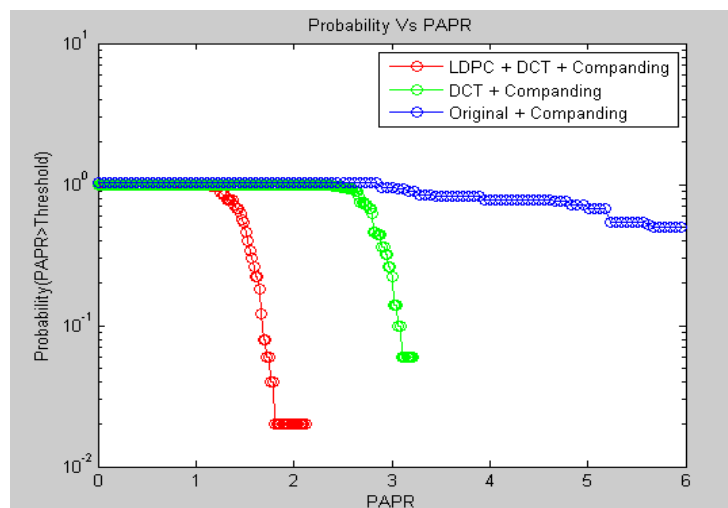

Fig 4 Comparisons of different PAPR reduction schemes

## **VII. CONCLUSIONS AND FUTURE WORKS**

In this paper, we proposed a combined LDPC and DCT with companding scheme for the reduction of the PAPR of OFDM signals. In the first step, the PAPR reduced by DCT and companding techniques. The simulation results show that the PAPR reduction is improved when compared with DCT and Companding techniques.

Future works will be continued in the following directions:

- (i) This technique may be extended to MIMO system with adaptive modulation.
- (ii) For unknown channel (no CSI) at the receiver, we must estimate the channel matrix, using an equalizer with LMS algorithm.
- (iii) Bit error rate (BER) performance.

## **REFERENCES**

- [1]. J.Kim and Y.Shin, "An effective clipping companding scheme for PAPR Reduction of OFDM Signal", IEEE International Conference on Communications, Beijing 2008.PP 668-672.
- [2]. M.Park, J.Heeyong, N.Cho, D.Hong and C.Karg, "PAPR Reduction in OFDM Transmission using Hadamard Transform", IEEE International Conference on Communications Vol.1. June 2000, PP 430-433.
- [3]. X.B.Wang, "Reduction of Peak-to-Average Power Ratio of OFDM System using a Companding Technique", IEEE Transaction on Broadcasting. Vol.45. No.3, 1999, PP 303-307.
- [4]. Zhongpeng wang, "Combined DCT and Companding for PAPR Reduction in OFDM Signals". Journal of Signal and Information Processing" Vol 2, 2012 PP 100-104.
- [5]. Hisashi Futaki, tomoaki Ohtsuki, "Performance of low-density parity check(LDPC) Coded OFDM Systems" PP 1696-1700, IEEE 2002.
- [6]. T.Jiang and Y.Imai, "An Overview: Peak-To-Average Power Ratio Reduction Techniques for OFDM Signals", IEEE Transactions on Broadcasting, Vol.54, No.2, 2008, PP 257-268.
- [7]. I.John, "RBF Neural Network Based SLM Peak-to-Average Power Ratio Reduction in OFDM Systems", EIRI Journal, Vol. 29, No.3, PP 402-404
- [8]. Heung – Gyoon Ryu, Cheng – Xiang Wang," Nonlinear distortion reduction for the improvement of the BER Performance in OFDM Communication Systems", ISCIT 2007, PP 67-71.
- [9]. Bernhard M.J Leiner, "LDPC Codes- A brief Tutorial", PP 1-9, 2008.
- [10]. S.H.Han and J.H Lee, "An Overview of Peak-to-Average Power Ratio Reduction Techniques for Multi Carrier Transmission", IEEE Transaction on wireless Communication, April 2005, PP 56-65.