

Design of A Novel Three Phase to SIX Phase Transformation Using a Special Transformer Connection

Mr. Merugu Mysaiah¹,

¹M-Tech Scholar, Power Electronics, SASI Institute of Technology and Engineering, Tadepalligudem (A.P), India.

Abstract—The first five-phase induction motor drive system was proposed in the late 1970s for adjustable speed drive applications. Since then, a considerable research effort has been in place to develop commercially feasible multiphase drive systems. Since the three-phase supply is available from the grid, there is a need to develop a static phase transformation system to obtain a multiphase supply from the available three-phase supply. Thus, this paper proposes a novel transformer connection scheme to convert the three phase grid supply to a five-phase fixed voltage and fixed frequency supply. The proposed transformer connection outputs five phases and, thus, can be used in applications requiring a five-phase supply. Currently, the five-phase motor drive is a commercially viable solution. The five-phase transmission system can be investigated further as an efficient solution for bulk power transfer. The connection scheme is elaborated by using the simulation and experimental approach to prove the viability of the implementation. The geometry of the fabricated transformer is elaborated in this paper.

Keywords—Five phase, multiphase, three phase, transformer, turn ratio.

I. INTRODUCTION

Multi phase (more than three phase) systems are the focus of research recently due to their inherent advantages compared to their three-phase counterparts. The applicability of multiphase systems is explored in electric power generation [2]–[8], transmission [9]–[15], and utilization [16]–[33]. The research on six-phase transmission system was initiated due to the rising cost of right of way for transmission corridors, environmental issues, and various stringent licensing laws. Six phase transmission lines can provide the same power capacity with a lower phase-to-phase voltage and smaller, more compact towers compared to a standard double-circuit three-phase line. The geometry of the six-phase compact towers may also aid in the reduction of magnetic fields as well [12]. The research on multiphase generators has started recently and only a few references are available [2]–[8]. The present work on multiphase generation has investigated asymmetrical six-phase (two sets of stator windings with 30 phase displacement) induction generator configuration as the solution for use in renewable energy generation. As far as multiphase motor drives are concerned, the first proposal was given by Ward and Harrer way back in 1969 [1] and since then, the research was slow and steady until the end of the last century.

The research on multiphase drive systems has gained momentum by the start of this century due to availability of cheap reliable semiconductor devices and digital signal processors. Detailed reviews on the state of the art in multiphase drive research are available in [18]–[22]. It is to be emphasized here that the multiphase motors are invariably supplied by ac/dc/ac converters. Thus, the focus of the research on the multiphase electric drive is limited to the modeling and control of the supply systems (i.e., the inverters [23]–[33]). Little effort is made to develop any static transformation system to change the phase number from three to n -phase (where 3 and odd). The scenario has now changed with this paper, proposing a novel phase transformation system which converts an available three-phase supply to an output five-phase supply.

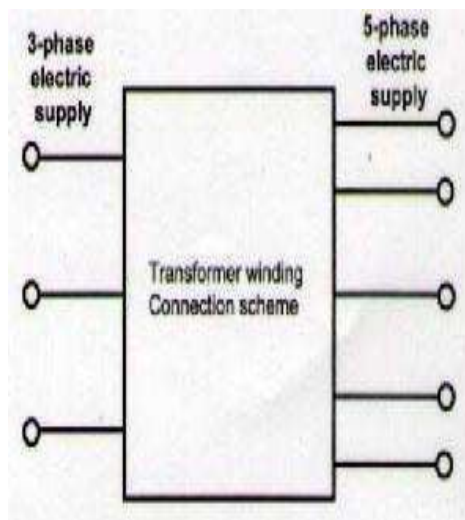

Fig. 1. Block representation of the proposed system.

Multiphase, especially a 6-phase and 12-phase system is found to produce less ripple with a higher frequency of ripple in an ac-dc rectifier system. Thus, 6- and 12-phase transformers are designed to feed a multi-pulse rectifier system and the technology has matured. Recently, a 24-phase and 36-phase transformer system has been proposed for supplying a multipulse rectifier system [34]–[37]. The reason of choice for a 6-, 12-, or 24-phase system is that these numbers are multiples of three and designing this type of system is simple and straightforward. However, increasing the number of phases certainly enhances the complexity of the system. None of these designs are available for an odd number of phases, such as 5, 7, 11, etc., as far as the authors know.

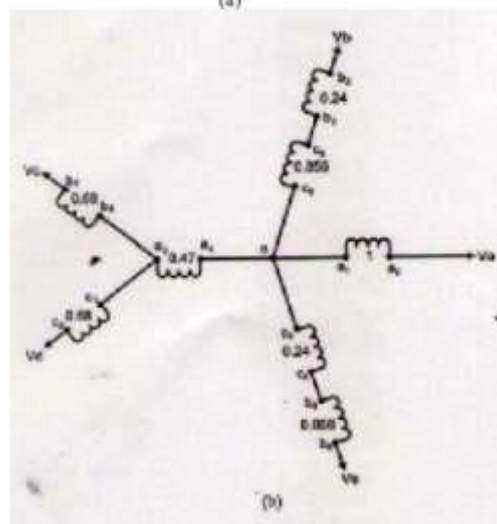
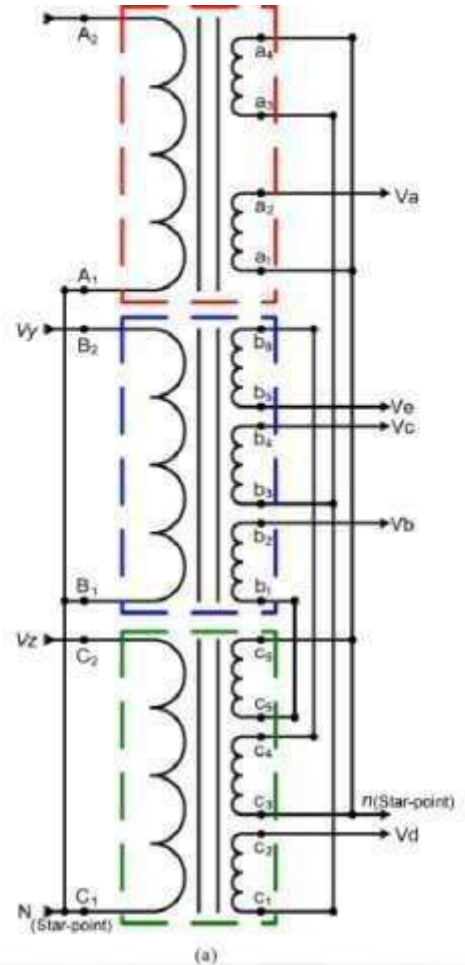

Fig. 2. (a) Proposed transformer winding arrangements (star-star). (b) Proposed transformer winding connection (star).

SFig. 3. Phasor diagram of the proposed transformer connection (star-star). The usual practice is to test the designed motor for a number of operating conditions with a pure sinusoidal supply to ascertain the desired performance of the motor [38]. Normally, a no-load test, blocked rotor, and load tests are performed on a motor to determine its parameters. Although the

supply used for a multiphase motor drive obtained from a multiphase inverter could have more current ripple, there are control methods available to lower the current distortion even below 1%, based on application and requirement. Hence, the machine parameters obtained by using the pulse width-modulated (PWM) supply may not provide the precise true value. Thus, a pure sinusoidal supply system available from the utility grid is required to feed the motor. This paper proposes a special transformer connection scheme to obtain a balanced five-phase supply with the input as balanced three phase. The block diagram of the proposed system is shown in Fig. 1. The fixed voltage and fixed frequency available grid supply can be transformed to the fixed voltage and fixed frequency five-phase output supply. The output, however, may be made variable by inserting the autotransformer at the input side. The input and output supply can be arranged in the following manner:

- 1) input star, output star;
- 2) input star, output polygon;
- 3) input delta, output star;
- 4) Input delta, output polygon.

Since input is a three-phase system, the windings are connected in an usual fashion. The output/secondary side connection is discussed in the following subsections.

II. WINDING ARRANGEMENT FOR FIVE-PHASE STAR OUTPUT:

Three separate cores are designed with each carrying one primary and three secondary coils, except in one core where only two secondary coils are used. Six terminals of primaries are connected in an appropriate manner resulting in star and/or delta connections and the 16 terminals of secondary's are connected in a different fashion resulting in star or polygon output. The connection scheme of secondary windings to obtain a star output is illustrated in Fig. 2 and the corresponding phasor diagram is illustrated in Fig. 3.

The construction of output phases with requisite phase angles of 72 between each phase is obtained using appropriate turn ratios, and the governing phasor equations are illustrated in (1)–(10). The turn ratios are different in each phase. The choice of turn ratio is the key in creating the requisite phase displacement in the output phases. The input phases are designated with letters —Xl —Yl, and —Zl and the output are designated with letters —Al, —Bl, —Cl, —Dl, and —El. As illustrated in Fig. 3, the output phase —Al is along the input phase —Xl. The output phase —Bl results from the phasor sum of winding voltage — l and — l, the output phase —Cl is obtained by the phasor sum of winding voltages — l and — l. The output phase —Dl is obtained by the phasor addition of winding voltages — l and — l and similarly output phase —El results from the phasor sum of the winding voltages — l and — l. In this way, five phases are obtained. The transformation from three to five and vice-versa is further obtained by using the relation given in (1)–(10)

$$\begin{bmatrix} V_a \\ V_b \\ V_c \\ V_d \\ V_e \end{bmatrix} = \frac{1}{\sin(\frac{\pi}{3})} \times \begin{bmatrix} \sin(\frac{\pi}{3}) & 0 & 0 \\ 0 & \sin(\frac{\pi}{15}) & -\sin(\frac{4\pi}{15}) \\ -\sin(\frac{2\pi}{15}) & \sin(\frac{\pi}{5}) & 0 \\ -\sin(\frac{4\pi}{15}) & 0 & \sin(\frac{\pi}{3}) \\ 0 & -\sin(\frac{4\pi}{15}) & \sin(\frac{\pi}{15}) \end{bmatrix} \begin{bmatrix} V_x \\ V_y \\ V_z \end{bmatrix} \quad (1)$$

$$V_a = V_{\max} \sin(\omega t) \quad (2)$$

S

TABLE I

DESIGN OF THE PROPOSED TRANSFORMER

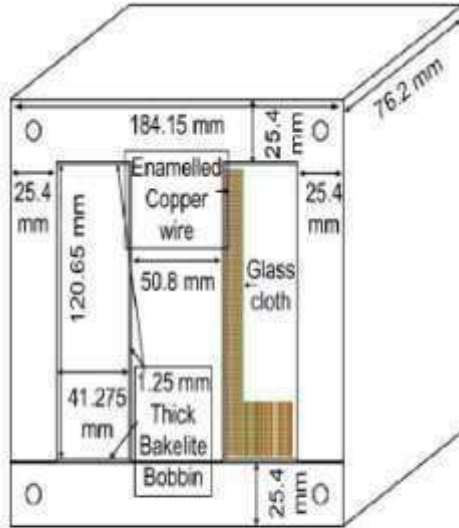

(a)

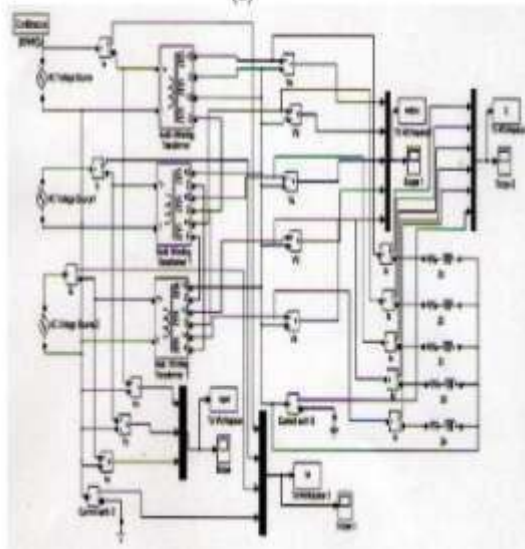

(b)

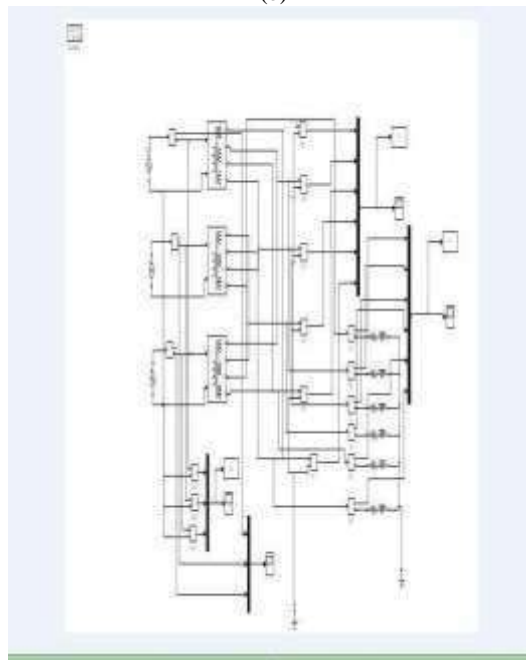

(c)

Fig.4(a)Geometry of the transformer, (b)Matlab/Simulink model of the three to six five transformation, (c) Mat lab/Simulink model of the three to six transformation

$$V_b = V_{max} \sin\left(\omega t + \frac{2\pi}{5}\right) \quad (3)$$

$$V_c = V_{max} \sin\left(\omega t + \frac{4\pi}{5}\right) \quad (4)$$

$$V_d = V_{max} \sin\left(\omega t - \frac{4\pi}{5}\right) \quad (5)$$

$$V_e = V_{max} \sin\left(\omega t - \frac{2\pi}{5}\right) \quad (6)$$

$$V_x = V_{max} \sin(\omega t) \quad (7)$$

$$V_y = V_{max} \sin\left(\omega t + \frac{2\pi}{3}\right) \quad (8)$$

$$V_z = V_{max} \sin\left(\omega t - \frac{2\pi}{3}\right) \quad (9)$$

III. SIMULATION RESULTS

The designed transformer is at first simulated by using —simpowersystem1 block sets of the Matlab/Simulink software. The inbuilt transformer blocks are used to simulate the conceptual design. The appropriate turn ratios are set in the

dialog box and the simulation is run. Turn ratios are shown in Table I. Standard wire gauge SWG) is shown in Table I. A brief design description for the turn ratio, wire gauge, and the geometry of the transformers [Fig. 4(a)] are shown in the Appendix. The simulation model is depicted in Fig. 4(b) and the resulting input and output voltage waveforms are illustrated in Fig. 5. It is clearly seen that the output is a balanced five-phase supply for a balanced three-phase input. Individual output phases are, also, shown along with their respective input voltages. The phase Va is not shown because (i.e., the input and the output phases are the same). There was no earth current flowing when both sides neutrals were earthed. The input and output currents with earth current waveforms are also shown in Fig. 5. From this, we can say that the transformer, connected to the X input line, carries 16.77% (19.5/16.7) more current than that of the other two transformers (or two phases). Due to this efficiency, the overall transformer set is slightly lower than the conventional three-phase transformer.

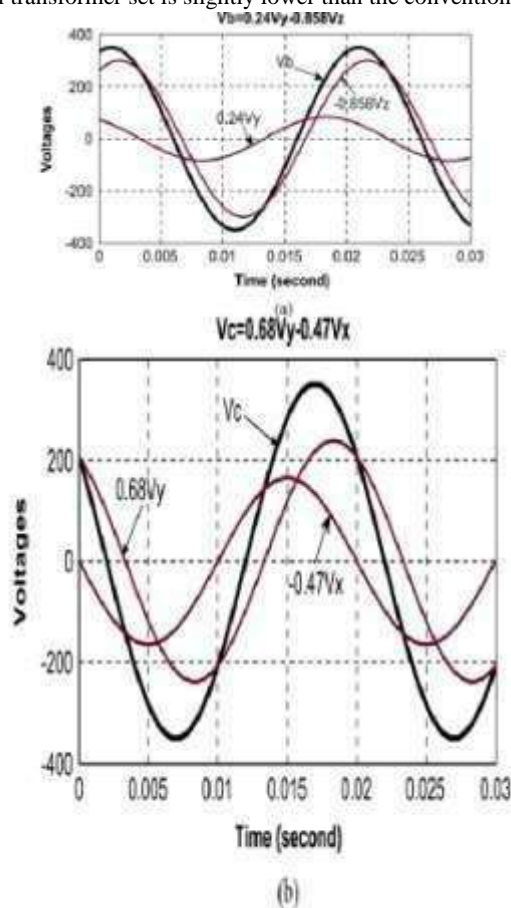

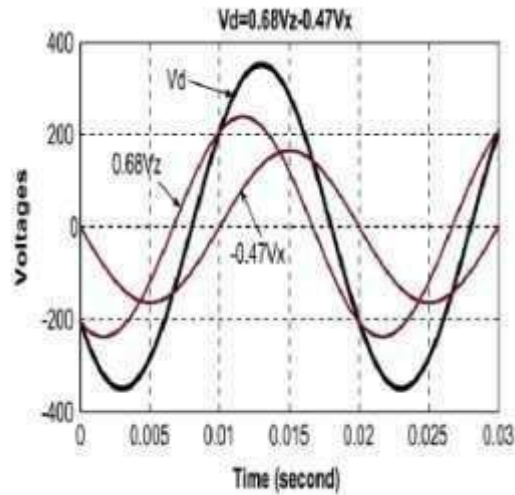

(c)

Fig. 5(a)–(c). (a) Input Vy and Vz phases and output Vb phase voltage waveforms. (b) Input Vy and Vx phases and output Vc phase voltage waveforms. (c) Input Vz and Vx phases and output Vd phase voltage waveforms.

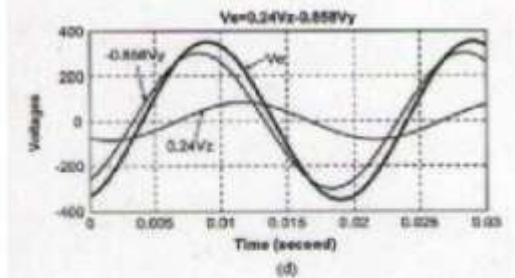

(d)

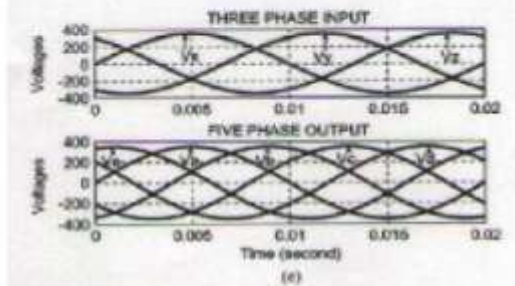

(e)

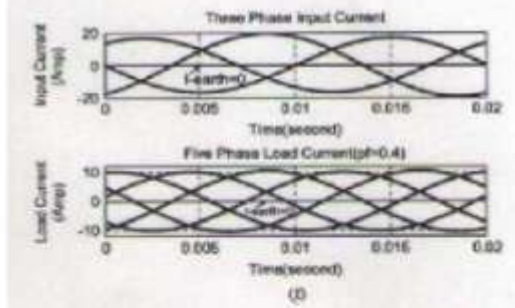

(f)

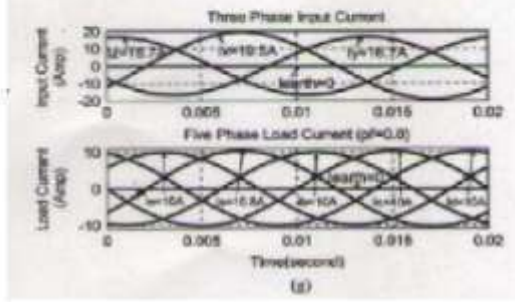

(g)

Fig. 5 (d)–(g). (d) Input Vz and Vy phases and output Ve phase voltage waveforms. (e) Input three-phase and output five-phase voltage waveforms. (f) Input three-phase and output five-phase load current waveforms at $\alpha = 0.4$. (g) Input three-phase and output five-phase load current waveforms at $\alpha = 0.8$.

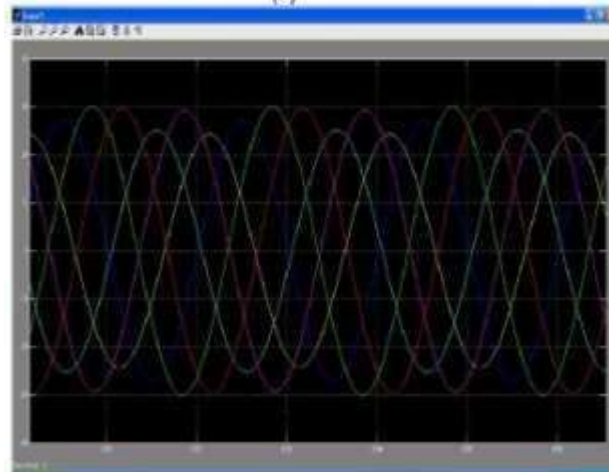
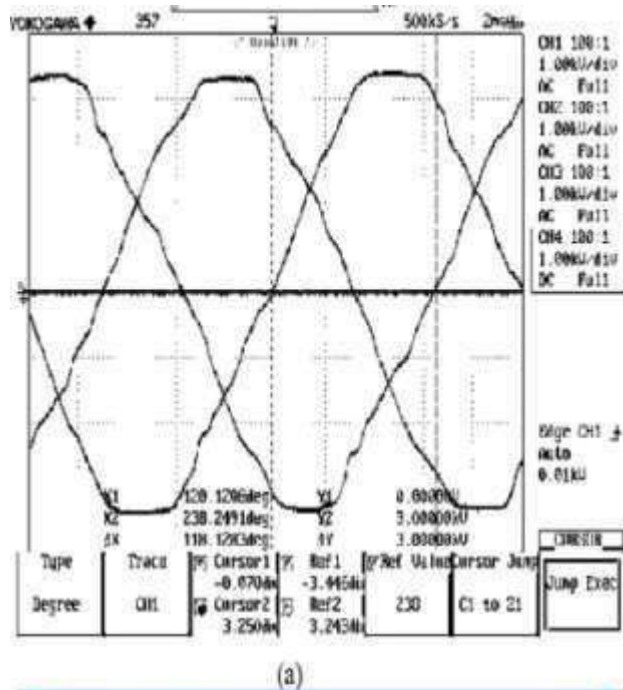

Fig. 6. (a) Input three-phase voltage waveform of the designed transformer primary. (b) SIX-phase output voltage waveform of the designed transformer secondary.

IV. EXPERIMENTAL RESULTS

This section elaborates the experimental setup and the results obtained by using the designed three- to five-phase transformation system. The designed transformation system has a 1:1 input:output ratio, hence, the output voltage is equal to the input voltage. Nevertheless, this ratio can be altered to suit the stepup or stepdown requirements. This can be achieved by simply multiplying the gain factor in the turn ratios. In the present scheme for experimental purposes, three singlephase autotransformers are used to supply input phases of the transformer connections. The output voltages can be adjusted by simply varying the taps of the autotransformer. For balanced output, the input must have balanced voltages. Any unbalancing in the input is directly reflected in the output phases. The input and output voltage waveforms under no-load steady-state conditions are recorded and shown in Fig. 6. The input and output voltage waveforms clearly show the successful implementation of the designed transformer. Since the input-power quality is poor, the same is reflected in the output as well. The output trace shows the no-load output voltages. Only four traces are shown due to the limited capability of the oscilloscope. Further tests are conducted under load conditions on the designed transformation system by feeding a five-phase induction motor.

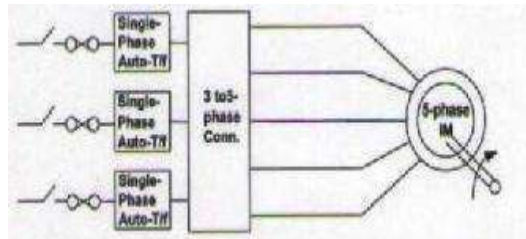

Fig. 7. Circuit diagram for a direct-online start of the five-phase motor.

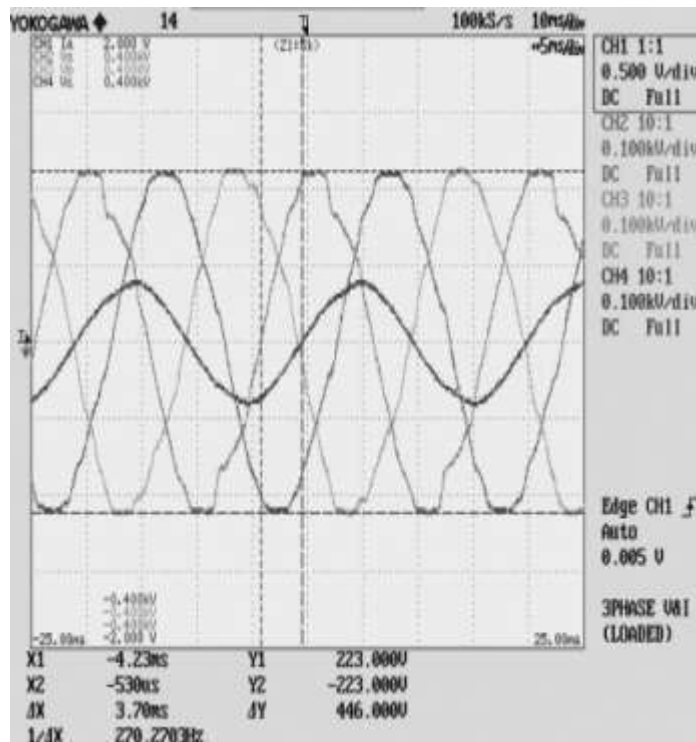

Fig. 8. Input side (three-phase) voltages and current waveform.

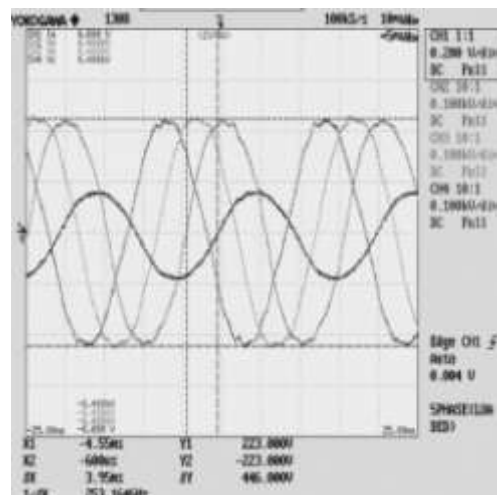
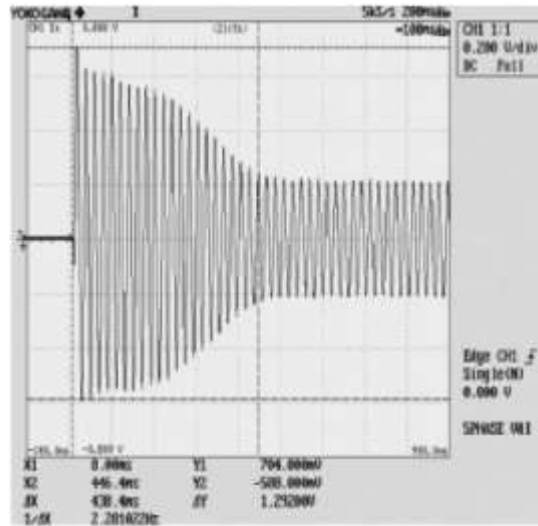
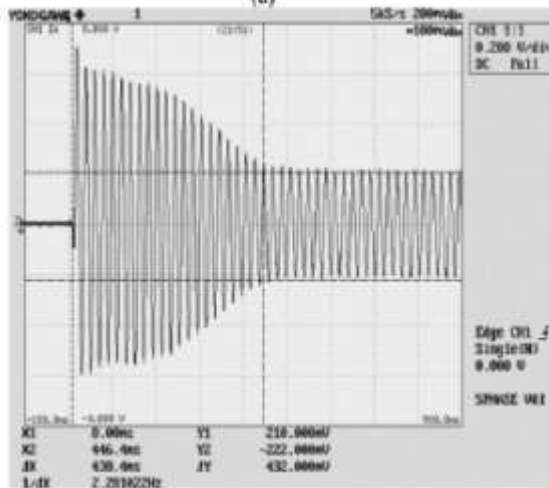

Fig. 9. Output side (five-phase) voltages and current waveform.



(a)



(b)

Fig. 10. (a) Initial inrush current of the three- to five-phase transformer showing a peak value under the transient condition.
 (b) Initial inrush current of the three- to five-phase transformer showing a peak value under the steady-state condition.

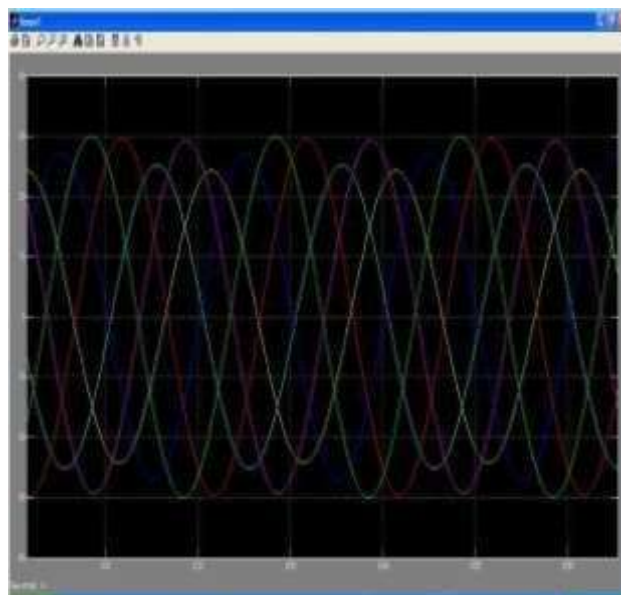

Figure 10 (c) Matlab/Simulink model of the SIX-phase voltages.

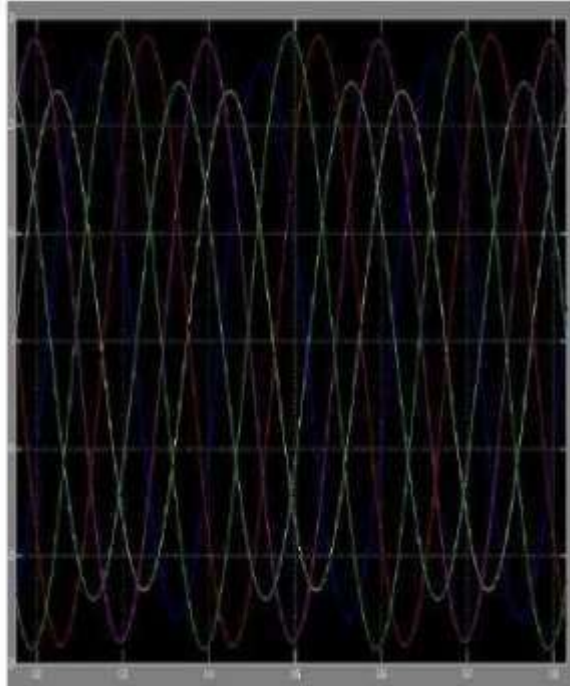

Figure 10 (d) Matlab/simulink model of the Six Phase currents.

The experimental setup is depicted in Fig. 7. Direct online starting is done for a five-phase induction motor which is loaded by using an eddy-current load system. DC current of 0.5 A is applied as the eddy current load on the five-phase induction machine. The resulting input (three-phase) waveforms and the output (five-phase) waveforms (voltages and currents) are shown in Figs. 8 and 9, respectively, under steady state. The applied voltage to the input side is 446 V (peak to peak), the power factor is 0.3971, and the steady-state current is seen as 7.6 A (peak-to-peak). The corresponding waveforms of the same phase —All are equal to the input side voltage of 446 (peak-to-peak), since the transformer winding has a 1:1 ratio. The power factor is now reduced in the secondary side and is equal to 0.324 and the steady-state current reduces to 3.3 A (peak-to-peak). The reduction in steady-state current is due to the increase in the number of output phases. Thus, once again, it is proved that the designed transformation systems work satisfactorily. The transient performance of the three-to five-phase transformer is evaluated by recording the transient current when supplying the five-phase induction motor load. The maximum peak transient current is recorded as 7.04 A which is reduced to 4.32 A in the steady-state condition. The settling time is recorded to be equal to 438.4 ms as depicted in Fig. 10.

V. CONCLUSION

This paper proposes a new transformer connection scheme to transform the three-phase grid power to a five-phase output supply. The connection scheme and the phasor diagram along with the turn ratios are illustrated. The successful implementation of the proposed connection scheme is elaborated by using simulation and experimentation. A five-phase induction motor under a loaded condition is used to prove the viability of the transformation system. It is expected that the proposed connection scheme can be used in drives applications and may also be further explored to be utilized in multiphase power transmission systems.

REFERENCES

- [1]. E. E. Ward and H. Harer, —Preliminary investigation of an inverter-fed 5-phase induction motor,| Proc. Inst. Elect. Eng., vol. 116, no. 6, 1969.
- [2]. D. Basic, J. G. Zhu, and G. Boardman, —Transient performance study of brushless doubly fed twin stator generator,| IEEE Trans. Energy Convers., vol. 18, no. 3, pp. 400–408, Jul. 2003.
- [3]. G. K. Singh, —Self excited induction generator research- a survey,| Elect. Power Syst. Res., vol. 69, pp. 107–114, 2004.
- [4]. O. Ojo and I. E. Davidson, —PWM-VSI inverter-assisted stand-alone dual stator winding induction generator,| IEEE Trans Ind. Appl., vol. 36, no. 6, pp. 1604–1611, Nov./Dec. 2000.
- [5]. G. K. Singh, K. B. Yadav, and R. P. Saini, —Modelling and analysis of multiphase (six-phase) self-excited induction generator,| in Proc. Eight Int. Conf. on Electric Machines and Systems, China, 2005, pp. 1922–1927.
- [6]. G. K. Singh, K. B. Yadav, and R. P. Sani, —Analysis of saturated multiphase (six-phase) self excited induction generator,| Int. J. Emerging Elect. Power Syst., Article 5, vol. 7, no. 2, Sep. 2006.
- [7]. G. K. Singh, K. B. Yadav, and R. P. Sani, —Capacitive self-excitation in six-phase induction generator for small hydro power-an experimental investigation,| presented at the IEEE Conf. Power Electronics, Drives and Energy Systems for Industrial Growth—2006 (PEDES-2006) PaperA- 20. (CD-ROM), New Delhi, India, Dec. 12–15, 2006.

- [8]. G. K. Singh, —Modelling and experimental analysis of a self excited six-phase induction generator for stand alone renewable energy generation, *Renew. Energy*, vol. 33, no. 7, pp. 1605–162, Jul. 2008.
- [9]. J. R. Stewart and D. D. Wilson, —High phase order transmission- a feasibility analysis Part-I-Steady state considerations, *IEEE Trans. Power App. Syst.*, vol. PAS-97, no. 6, pp. 2300–2307, Nov. 1978.
- [10]. J. R. Stewart and D. D. Wilson, —High phase order transmission- a feasibility analysis Part-II-Over voltages and insulation requirements, *IEEE Trans. Power App. Syst.*, vol. PAS-97, no. 6, pp. 2308–2317, Nov. 1978.
- [11]. 1978.
- [12]. J. R. Stewart, E. Kallaur, and J. S. Grant, —Economics of EHV high\ phase order transmission, *IEEE Trans. Power App. Syst.*, vol. PAS- 103, no. 11, pp. 3386–3392, Nov. 1984.
- [13]. S. N. Tewari, G. K. Singh, and A. B. Saroor, —Multiphase power transmission research-a survey, *Elect. Power Syst. Res.*, vol. 24, pp. 207–215, 1992.
- [14]. C. M. Portela and M. C. Tavares, —Six-phase transmission line-propagation characteristics and new three-phase representation, *IEEE Trans. Power Del.*, vol. 18, no. 3, pp. 1470–1483, Jul. 1993.
- [15]. T. L. Landers, R. J. Richeda, E. Krizanskas, J. R. Stewart, and R. A. Brown, —High phase order economics: Constructing a new transmission line, *IEEE Trans. Power Del.*, vol. 13, no. 4, pp. 1521–1526, Oct. 1998.
- [16]. J. M. Arroyo and A. J. Conejo, —Optimal response of power generators to energy, AGC, and reserve pool based markets, *IEEE Power Eng. Rev.*, vol. 22, no. 4, pp. 76–77, Apr. 2002.
- [17]. M. A. Abbas, R. Chirsten, and T. M. Jahns, —Six-phase voltage source inverter driven induction motor, *IEEE Trans. Ind. Appl.*, vol. IA-20, no. 5, pp. 1251–1259, Sep./Oct. 1984.
- [18]. K. N. Pavithran, R. Parimelalagan, and M. R. Krsihnamurthy, —Studies on inverter fed five-phase induction motor drive, *IEEE Trans. Power Electron.*, vol. 3, no. 2, pp. 224–235, Apr. 1988.
- [19]. G. K. Singh, —Multi-phase induction machine drive research—a survey, *Elect. Power Syst. Res.*, vol. 61, pp. 139– 147, 2002.
- [20]. M. Jones and E. Levi, —A literature survey of the state-of-the-art in multi-phase ac drives, *in Proc. Int. UPEC, Stafford, U.K.*, 2002, pp. 505–510.
- [21]. R. Bojoi, F. Farina, F. Profumo, and A. Tenconi, —Dual-three phase induction machine drives control—A survey, *Inst. Elect. Eng. Jpn. Trans. Ind. Appl.*, vol. 126, no. 4, pp. 420–429, 2006.
- [22]. E. Levi, R. Bojoi, F. Profumo, H. A. Toliyat, and S. Williamson, —Multiphase induction motor drives-A technology status review, *Inst. Eng. Technol. Electr. Power Appl.*, vol. 1, no. 4, pp. 489–516, Jul. 2007.
- [23]. E. Levi, —Multiphase electric machines for variable-speed applications, *IEEE Trans Ind. Electron.*, vol. 55, no. 5, pp. 1893–1909, May 2008.
- [24]. A. Iqbal and E. Levi, —Space vector PWM techniques for sinusoidal output voltage generation with a five-phase voltage source inverter, *Elect. Power Components Syst.*, vol. 34, no. 2, 2006.
- [25]. A. Iqbal and E. Levi, —Space vector modulation schemes for a fivephase voltage source inverter, *presented at the Eur. Power Electron. Conf. EPE (CD-ROM.pdf)*, Dresden, Germany, 2005.
- [26]. M. Jones, —A novel concept of a multi-phase multi-motor vector controlled drive system, *Ph.D. dissertation, Liverpool John Moores Univ., Liverpool, U.K.*, 2005.
- [27]. A. Iqbal, —Modelling and control of series-connected five-phase and six-phase two-motor drive, *Ph.D. dissertation, Liverpool John Moores Univ., Liverpool, U.K.*, 2006.
- [28]. H. M. Ryu, J. H. Kim, and S. K. Sul, —Analysis of multi-phase space vector pulse width modulation based on multiple d-q spaces concept, *presented at the Int. Conf. Power Electronics and Motion Control IPEMC (CD-ROM Paper 2183.pdf.)*, Xian, China, 2004.
- [29]. O. Ojo and G. Dong, —Generalized discontinuous carrier-based PWM modulation scheme for multi-phase converter-machine systems, *presented at the IEEE Ind. Appl. Soc. Annu. Meet. IAS (CD-ROM Paper no. 38P3)*, Hong Kong, China, 2005.
- [30]. D. Dujic, M. Jones, and E. Levi, —Generalised space vector PWM for sinusoidal output voltage generation with multiphase voltage source inverter, *Int. J. Ind. Elect. Drives*, vol. 1, no. 1, pp. 1–13, 2009.
- [31]. M. J. Duran, F. Salas, and M. R. Arahal, —Bifurcation analysis of five-phase induction motor drives with third harmonic injection, *IEEE Trans. Ind. Electron.*, vol. 55, no. 5, pp. 2006–2014, May 2008.
- [32]. M. R. Arahal and M. J. Duran, —Pi tuning of five-phase drives with third harmonic injection, *Control Eng. Practice*, vol. 17, pp. 787–797, Feb. 2009.
- [33]. D. Dujic, M. Jones, and E. Levi, —Analysis of output current ripple rms in multiphase drives using space vector approach, *IEEE Trans. Power Electron.*, vol. 24, no. 8, pp. 1926–1938, Aug. 2009.
- [34]. V. Garg, B. Singh, and G. Bhuvaneswari, —A tapped star connected autotransformer based 24-Pulse AC-DC converter for power quality improvement.

Authors:



Merugu Mysaiah, M-Tech Scholar, power Electronics, Department Of Electrical And Electronics Engineering, SASI institute of Technology and Engineering Tadepalligudem(AP) He Completed B.Tech with specialization of E.E.E in Lakki Reddy College of Engineering in the year 2010.