

Improvement Of Voltage Quality Of Micro Turbine Generator With Matrix Converter & Venturini Technique's

¹N.Mallikarjuna, ²S.Muqthiar ali, ³Dr.M.Padma Lalitha

¹Student, ²Assistant professor, ³Professor &HOD Department of Electrical and Electronics Engineering
 Annamacharya Institute of Technology & Sciences, Rajampet-516216(INDIA)

Abstract:- In recent years, application of Distributed Generation (DG) sources has increased significantly. Micro turbine-Generator (MTG) is well suitable for different distributed generation applications, because it can be connected in parallel to serve larger loads, can provide reliable power and has low-emission. The main characteristics of MTG can be summarized in low maintenance, capacity of operation with liquid and gas fuels (including natural gas) and small area required for installation [1].

MTGs have the rated power from 30 to 250 kW, generating electricity in ac, and they can be installed in isolated conditions or synchronized with the electrical utility. MTGs are available as single-shaft or split-shaft units. Single-shaft unit is a high-speed synchronous machine with the compressor and turbine mounted on the same shaft. While, the split-shaft design uses a power turbine rotating at 3000 rpm and a conventional generator connected via a synchronous generator-PMSG, frequency converters (interface converters), and protection and control systems (Fig. 1)[1]. The interface converter is used to convert PMSG output voltage frequency (high frequency) to power system (50/60 Hz) frequency.

Keywords:- Micro- turbine Genrator (MTG), Distributed generators, Matrix Converter (MC), Harmonics (H),

I. INTRODUCTION

In this paper, the model proposed in is considered for micro turbine. The modeling of micro turbine has been done in Matlab/Simulink (Fig. 2). As can be seen in Fig. 2, the model is made up of speed controller, acceleration controller, temperature controller and fuel system (including valve positioned and actuator). The exhaust temperature function f_1 and torque function f_2 is given by,

$$f_1 = T_R - 700(1 - W_{f1}) + 550(1 - \omega) \dots \dots \dots (1)$$

$$f_2 = 1.3(W_{f2} - 0.23) + 0.5(1 - \omega) \dots \dots \dots (2)$$

Where ω denotes turbine speed, W_{f1} and W_{f2} are fuel flows signals, and T_R denotes rated exhaust temperature.

II. MICRO TURBINE MODELING

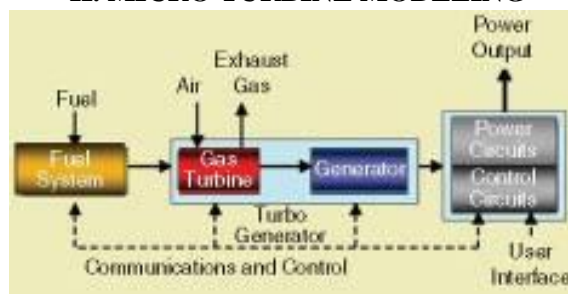

Fig.1 Block diagram of a single – shaft MTG

III. MATRIX CONVERTER (MC)

MC is an array of controlled semiconductor switches that connects directly the three-phase source to the three-phase load. In the other words, MC performs a direct AC/AC conversion. While, AC/AC conversion is conventionally achieved by a rectifier stage, a dc link and an inverter stage. Since, in the MC the switching is performed on sinusoidal waveforms, the output voltage quality can be better than the conventional rectifier-inverter structure. Also, there is no dc-link (large energy storage element) in MC. So, the MC is more compact compared to conventional AC/AC converters [5,6]. A common matrix converter structure consisting of 3x3 switches is shown in Fig. 3. As can be seen, it connects a three-phase voltage source to a three-phase load [6].

The matrix converter requires a bidirectional switch capable of blocking voltage and conducting current in both directions. Unfortunately, there are no such devices currently available, so discrete devices need to be used to construct suitable switch cells. In this paper, the common-emitter back to back structure is used as bidirectional switch. The Simulink model of this switch is shown in Fig. 4.

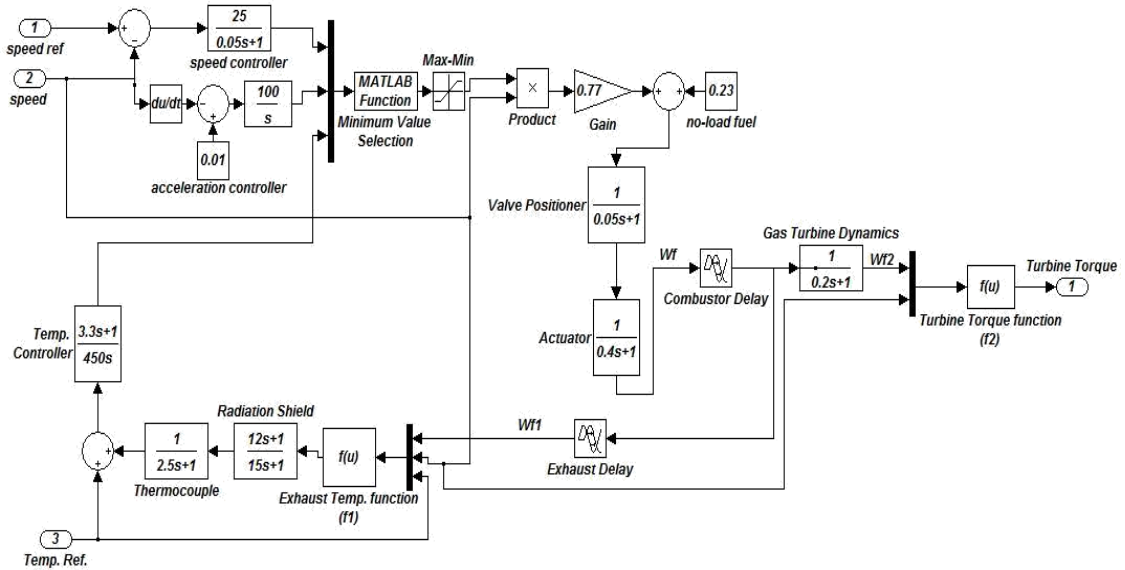

Fig.2 Micro turbine model

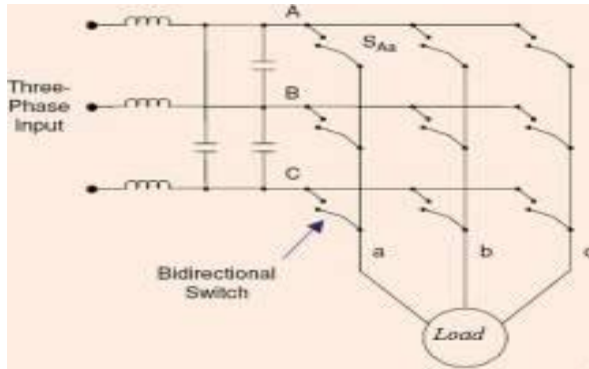

Fig.3 Basic MC Structure

Normally, the matrix converter is fed by a voltage source and, for this reason; the input terminals should not be short circuited. On the other hand, the load has typically an inductive nature and, for this reason, an output phase must never be opened [5]. Considering fig.3 and defining the switching function of a single switch as [5].

$$S_{kj} = \begin{cases} 1 & \text{switch } S_{kj} \text{ closed} \\ 0 & \text{switch } S_{kj} \text{ open} \end{cases} \dots\dots\dots(3)$$

where $K = \{ A, B, C \}$ $j = \{ a, b, c \}$

The constraints discussed above can be expressed by:
 $S_{Aj} + S_{Bj} + S_{Cj} = 1, \quad j = \{ a, b, c \} \dots$ (4)

The load and source voltages of Fig. 3 with reference to supply neutral are considered as follows:

$$V_0 = \begin{bmatrix} V_a(t) \\ V_b(t) \\ V_c(t) \end{bmatrix} \quad V_i = \begin{bmatrix} V_A(t) \\ V_B(t) \\ V_C(t) \end{bmatrix} \quad (5)$$

So, it can be written that:

$$\begin{bmatrix} V_a(t) \\ V_b(t) \\ V_c(t) \end{bmatrix} = \begin{bmatrix} S_{Aa}(t) & S_{Ba}(t) & S_{Ca}(t) \\ S_{Ab}(t) & S_{Bb}(t) & S_{Cb}(t) \\ S_{Ac}(t) & S_{Bc}(t) & S_{Cc}(t) \end{bmatrix} \begin{bmatrix} V_A(t) \\ V_B(t) \\ V_C(t) \end{bmatrix} \quad (6)$$

$$V_0 = T \cdot V_i$$

Where T is the instantaneous transfer matrix.

In order to derive modulation rules, it is also necessary to consider the switching pattern that is employed. This typically follows a form similar to that shown in Fig. 5.

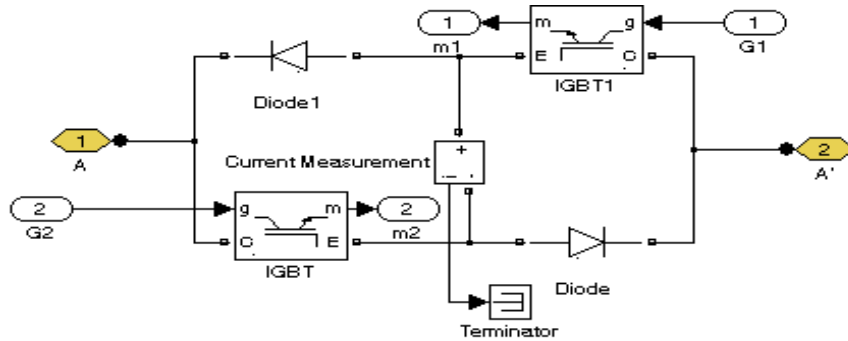

Fig.4 simulink model of bidirectional switch

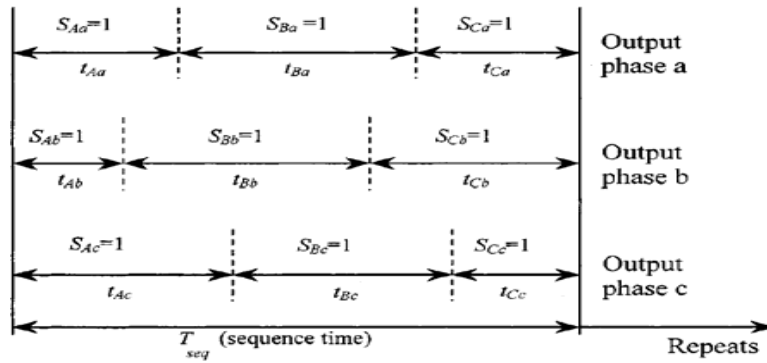

Fig.5 switching pattern

By considering that the bidirectional power switches work with high switching frequency, a low-frequency output voltage of variable amplitude and frequency can be generated by modulating the duty cycle of the switches using their respective switching functions.

Let $m_{kj}(t)$ be the duty cycle of switch S_{kj} , defined as $m_{kj}(t) = t_{kj} / T_{seq}$, which can have the following values:

$$0 < m_{Kj} < 1, \quad K = \{A, B, C\} \quad j = \{a, b, c\} \quad (7)$$

The low-frequency transfer matrix is defined by:

$$M(t) = \begin{bmatrix} m_{Aa}(t) & m_{Ba}(t) & m_{Ca}(t) \\ m_{Ab}(t) & m_{Bb}(t) & m_{Cb}(t) \\ m_{Ac}(t) & m_{Bc}(t) & m_{Cc}(t) \end{bmatrix} \quad (8)$$

The low-frequency component of the output phase voltage is given by:

$$\bar{V}_0 = M(t)V_i(t) \quad (9)$$

Some modulation techniques have been presented for MC control. The most popular of them are Venturini, Scalar, and Space Vector Modulation (SVM) methods [5].

In this paper, the Venturini method is applied for MC control. In this method, switching timing can be expressed in terms of the input voltages and the target output voltages, as follows:

The original algorithm proposed by venturini is:

$$m_{ij} = \frac{1}{3} \left[1 + \frac{2v_{if}v_{oj}}{\hat{v}_i^2} \right], \quad i, j = 1, 2, 3 \quad (10)$$

The well known main problem of this algorithm is that it has a limited ratio $r < 0.5$ which is limiting the use of this method. The expression of the modulation coefficients for this algorithm can be presented as follows

$$\begin{aligned}
 m_{11} &= \frac{1}{3} + \cos(\Delta\omega t) \dots \\
 m_{12} &= \frac{1}{3} + \cos(\Delta\omega t - \frac{2\pi}{3}) \\
 m_{13} &= \frac{1}{3} + \cos(\Delta\omega t - \frac{4\pi}{3}) \\
 m_{21} &= \frac{1}{3} - \sqrt{3}\alpha_1 \sin(\Delta\omega t) + \cos(\Delta\omega t - \frac{2\pi}{3}) \\
 m_{22} &= \frac{1}{3} - \sqrt{3}\alpha_1 \sin(\Delta\omega t - \frac{2\pi}{3}) + \cos(\Delta\omega t - \frac{4\pi}{3}) \\
 m_{23} &= \frac{1}{3} - \sqrt{3}\alpha_1 \sin(\Delta\omega t - \frac{4\pi}{3}) + \cos(\Delta\omega t) \\
 m_{31} &= \frac{1}{3} + \sqrt{3}\alpha_1 \sin(\Delta\omega t) + \cos(\Delta\omega t - \frac{4\pi}{3}) \\
 m_{32} &= \frac{1}{3} + \sqrt{3}\alpha_1 \sin(\Delta\omega t - \frac{2\pi}{3}) + \cos(\Delta\omega t) \\
 m_{33} &= \frac{1}{3} + \sqrt{3}\alpha_1 \sin(\Delta\omega t - \frac{4\pi}{3}) + \cos(\Delta\omega t - \frac{2\pi}{3})
 \end{aligned}$$

With: $\Delta\omega = \omega_o - \omega_i$ and $\alpha_1 = \frac{V_o}{3V_i}$

Based on the technique so called the technique of the neutral point, the r ratio can go up to 0.866 without passing through the over-modulation region by adding the Zero vector to the reference output voltage which was defined before.

$$v_{oj} = r \cdot \hat{v}_i \cdot \begin{bmatrix} \cos(\omega_o t + (i+1)\frac{2\pi}{3}) \\ -\frac{1}{6}\cos(3\omega_o t) \\ +\frac{1}{2\sqrt{3}}\cos(3\omega_i t) \end{bmatrix}$$

Where: $V_{Zero} = -\frac{1}{6}\cos(3\omega_o t) + \frac{1}{2\sqrt{3}}\cos(3\omega_i t)$

v_{oi} is the new reference output voltage. Finally the simplified expression of Venturini is obtained:

$$m_{ij} = \frac{1}{3} \left[1 - \frac{2v_{oi}v_{oj}}{v_i^2} + \frac{4r}{3\sqrt{3}} \sin(\omega_i t - \beta_i) \cdot \sin(3\omega_i t) \right] \quad (11)$$

$i, j = 1, 2, 3$ and $\beta_i = 0, 2\pi/3, 4\pi/3$

The calculation of m_{ij} is performed at a sampling frequency which also defines the converter switching frequency.

IV. SIMULATION RESULTS

In this section, the MTG is simulated in Matlab/Simulink. The model of PMSG available at Simulink library is used for generator simulation. This PMSG has 8 poles and its rated power is 30kW. In simulations, the focus will be on comparison of output voltage quality of two MTG interface converters (matrix converter with venturini technique and conventional rectifier-inverter structure). In order to perform a true comparison, switching frequency of both converters is set to 5kHz and output LC filters parameters are chosen to be the same. The block diagram of the simulated system is shown in Fig. 6.

The reference speed of the MTG is set to 45000 rpm. At first, The RLC load is 0.2 pu. Then, at $t=14$ sec, the load has a step increase to 0.8 pu.

The torque response of the micro turbine is compared with the load demand in Fig. 7. It can be seen that the torque has a good convergence.

Also, speed of MTG is shown in Fig.8. As it can be observed, the speed converges to its reference value, too.

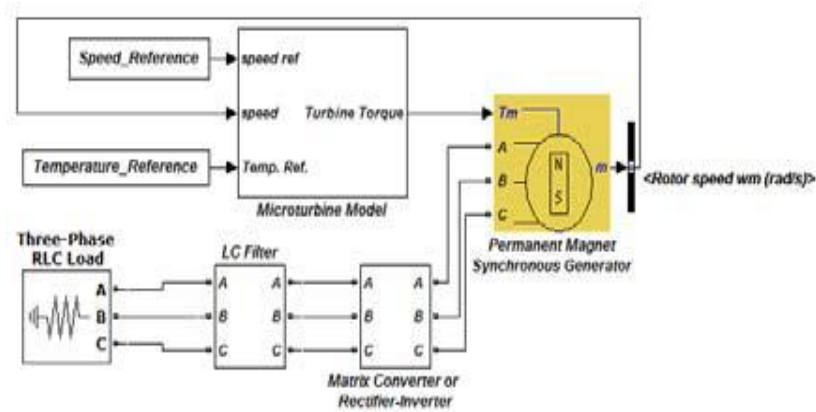

Fig.6 Simulated system

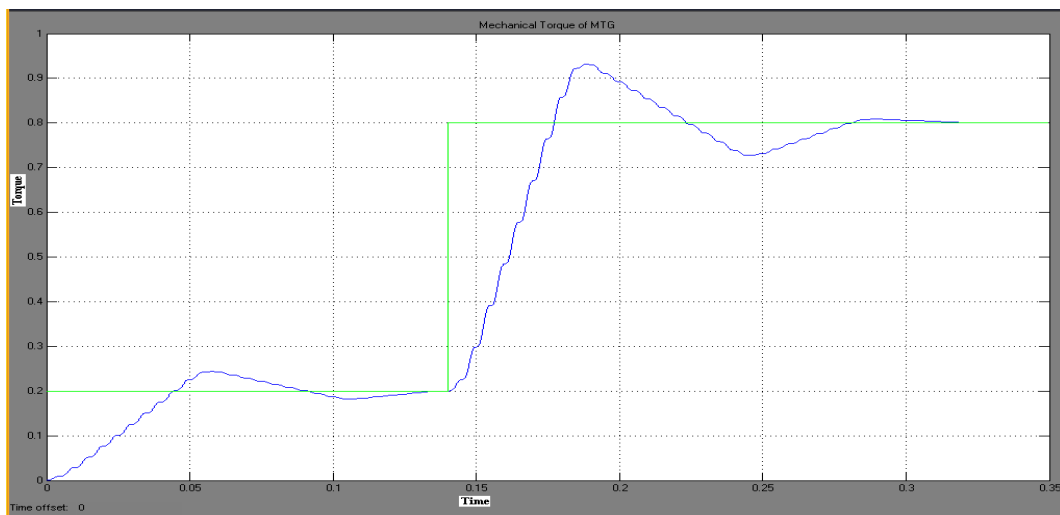

Fig.7 mechanical torque of MTG

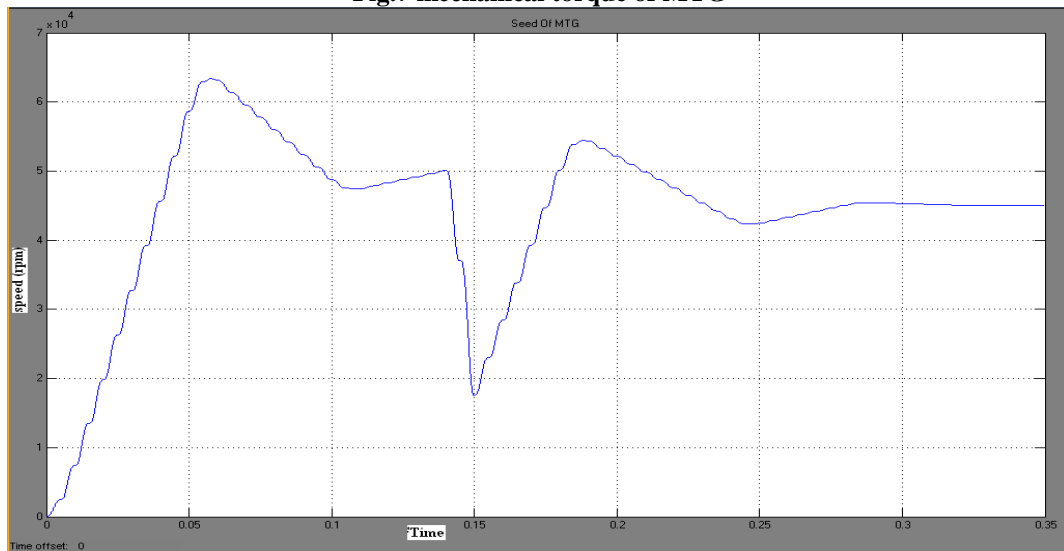

Fig.8 Speed of MTG

At this speed, the output frequency of the PMSG is 3000Hz and must be converted to power system frequency (60Hz). As it is mentioned earlier, it can be achieved using matrix converter or conventional rectifier-inverter structure. In Figs 9(a) and 9(b), PMSG output phase voltages at 0.2 pu and 0.8 pu loads are shown

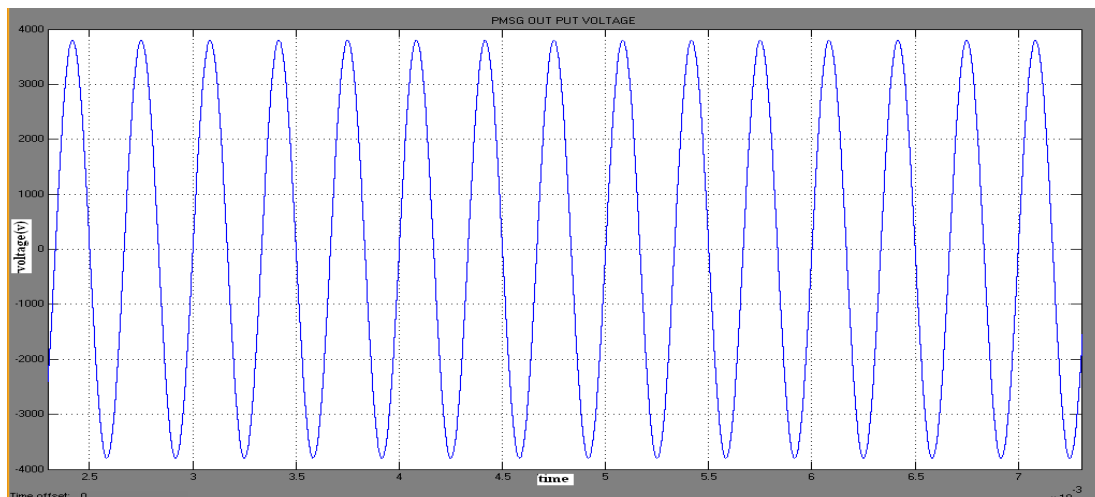

Fig.9 (a) PMSG output voltage:(a)load=0.2pu

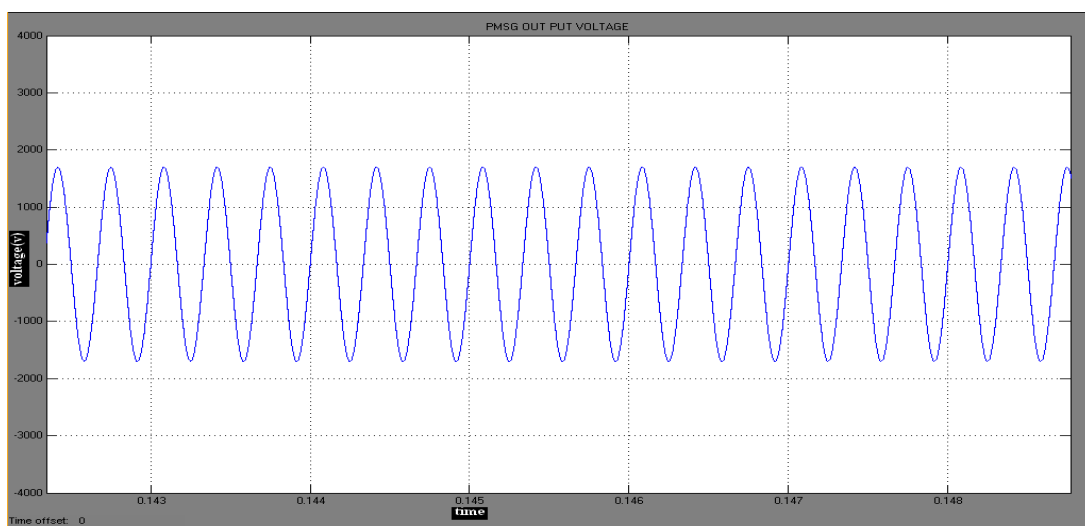

Fig.9 (b) PMSG output voltage:(a)load=0.8pu

Matrix and conventional converters operate on these load voltages to construct a 60Hz, 440V(p-p) output voltage. Output waveforms of these converters before filtering are shown in Figs. 10 and 11, respectively.

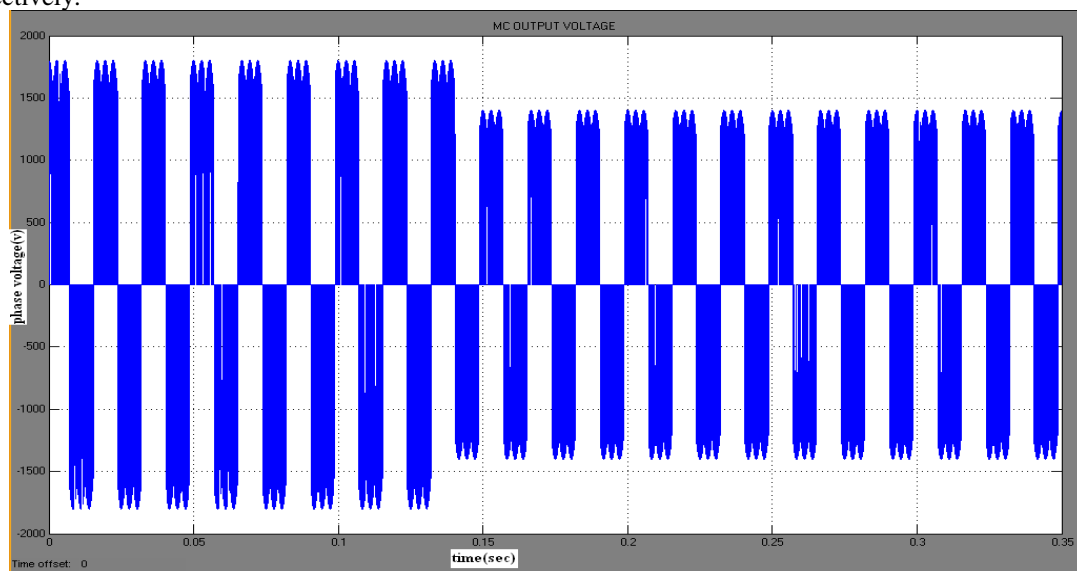

Fig.10. MC output voltage: load= 0.2 pu (left) load=0.8 pu (right)

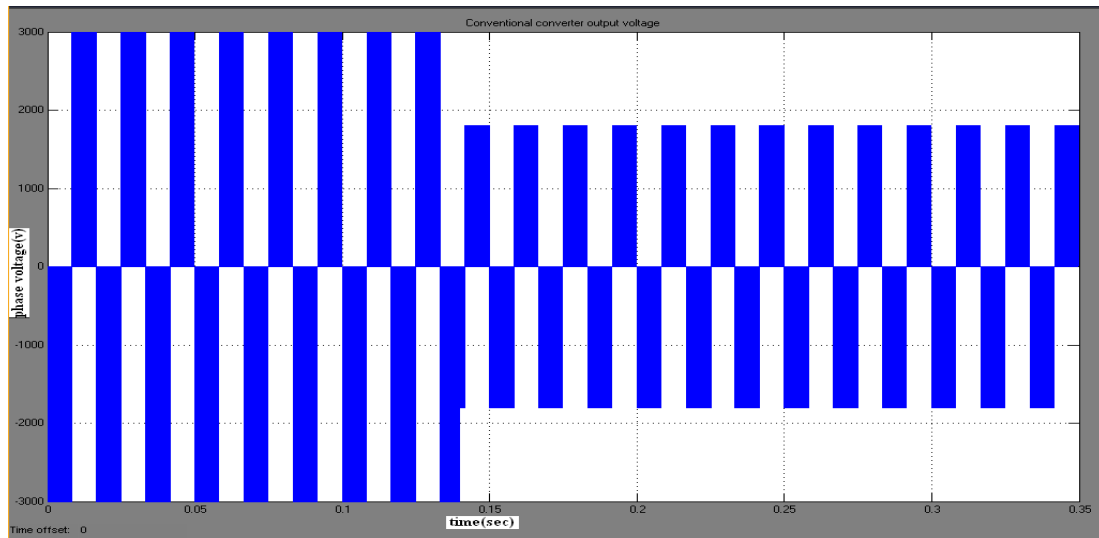

Fig.11. Conventional converter output voltage: load= 0.2 pu (left) load=0.8 pu (right)

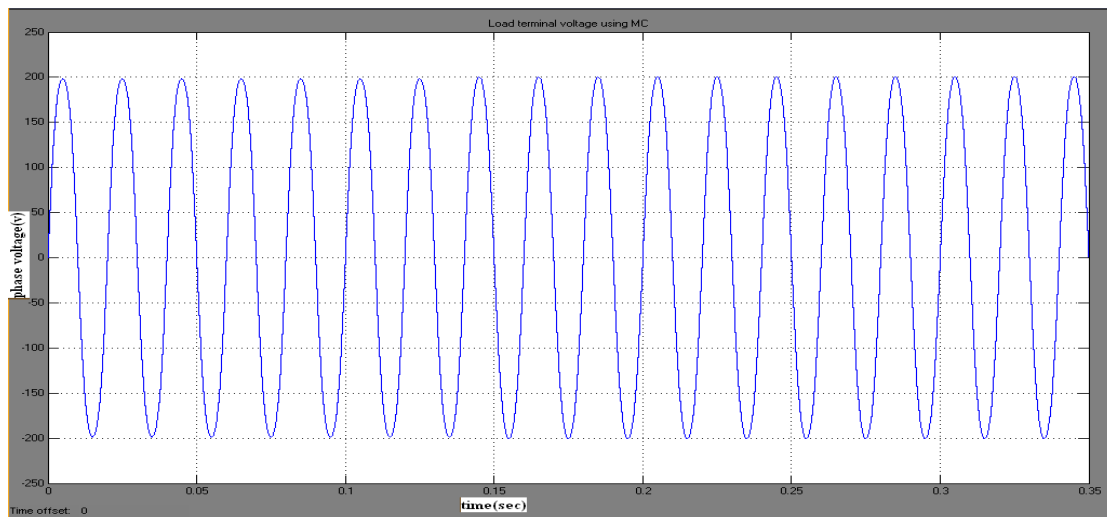

Fig.12. load terminal voltage using MC: load= 0.2 pu and load=0.8 pu

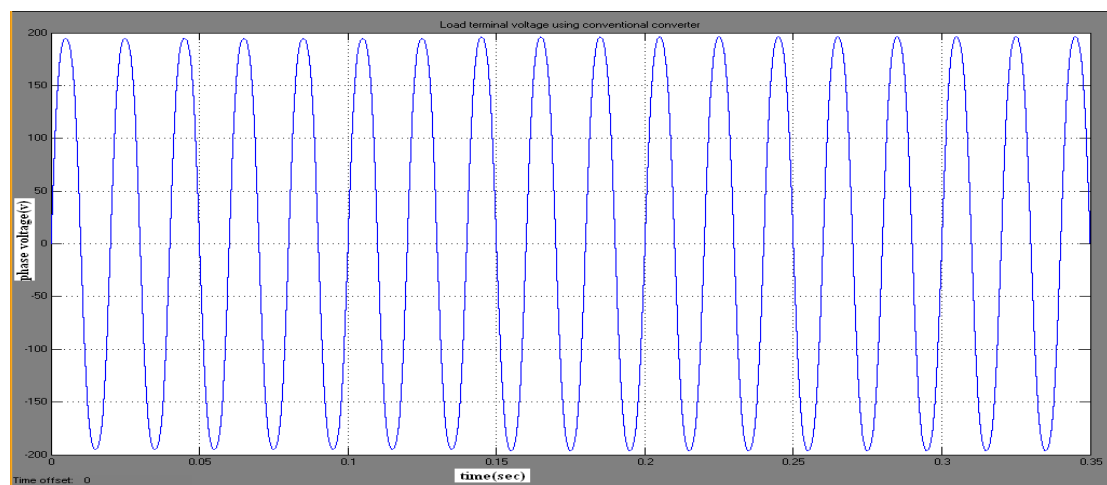

Fig.13. load terminal voltage using conventional converter: load= 0.2 pu and load=0.8 pu

These voltages are filtered by the LC filter to construct the load terminal voltages. Figs 12 and 13 show the filtered voltages waveforms. As it can be seen, the voltage THD values (5.5% and 4.5% for 0.2 and 0.8 pu loads) using MC are less than the ones in the case of conventional rectifier-inverter structure (7.2% and 6.5% for 0.2 and 0.8 pu loads).

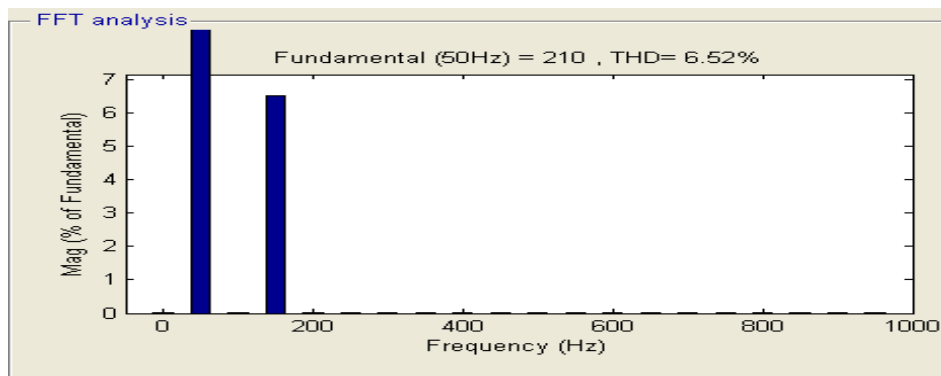
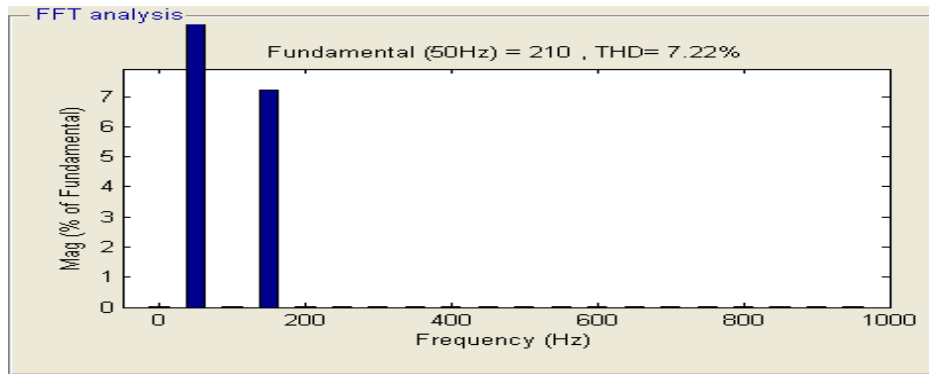

Fig.14 THD values for conventional converter (7.2% and 6.5% for 0.2 and 0.8pu load)

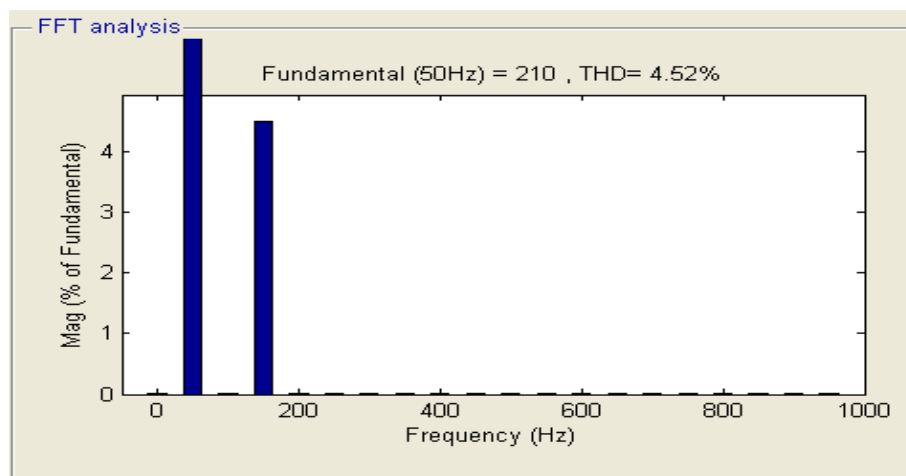
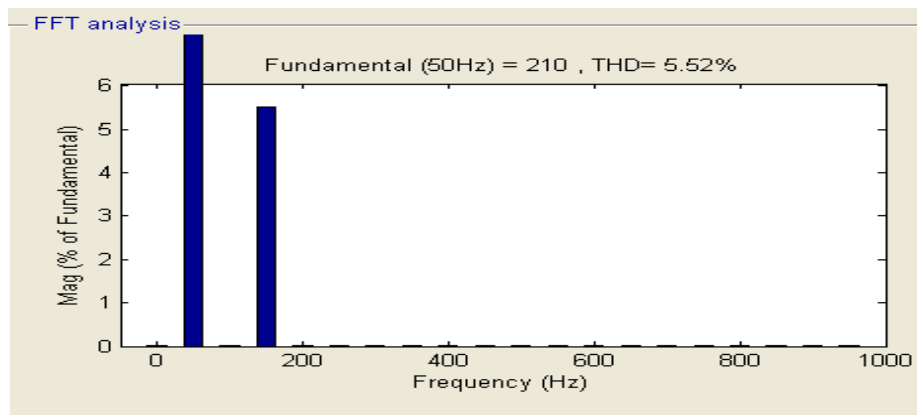

Fig.15 THD values for MC (5.5% and 4.5% for 0.2 and 0.8pu load)

V. CONCLUSIONS

In this paper, application of the matrix converter with venturini technique as output frequency converter in microturbine-generator is addressed. Comparison of simulation results of MTG using matrix converter and conventional interface converters demonstrated the ability of MC to deliver a higher-quality voltage to the load.

A venturini based compensation technique is proposed to improve the output performance of the MC. The proposed method has satisfactorily reduced harmonics in the output currents and voltages under the distorted input voltage conditions. In addition to, this method allows the over-current protection and the control of the load current.

Also, it is worthy to be noted that through application of MC the large dc link capacitor which is common in the rectifier-inverter structure is omitted. So; the matrix interface converter can be more compact and less expensive.

REFERENCES

- [1]. A. K. Saha, S. Chowdhury, S. P. Chowdhury, and P. A. Crossley, "Modeling and performance analysis of a microturbine as a distributed energy resource", *IEEE Trans. Energy Conv.*, vol. 24, no. 2, pp. 529-538, Jun. 2009.
- [2]. T. Yu, J. Tong, and K. W. Chan, "Study on microturbine as a back-up power supply for power grid black-start", *IEEE Int. Conf.* 2009.
- [3]. R. Noroozian, M. Abedi, G. B. Gharehpetian, and S. H. Hosseini, "Modelling and simulation of microturbine generation system for on-grid and off-grid operation modes", *Int.l Conf. on Renewable Energies and Power Quality (ICREPQ'09)*, Apr. 2009.
- [4]. A.P. W. Wheeler, J. Rodriguez, J. C. Clare, L. Empringham, and Weinstein, "Matrix Converters: A Technology Review", *IEEE Trans. Ind. Elec.*, vol. 49, no. 2, pp. 276-288, Apr. 2002.
- [5]. G.P. W. Wheeler, J. C. Clare, L. Empringham, M. Bland, and K.G. Kerris, "A vector-controlled MCT matrix converter induction motor drive with minimized commutation time and enhanced waveform quality", *IEEE Ind. Appl. Mag.*, pp. 59-65, Jan./Feb. 2004.
- [6]. E. F. Pavinatto, M. B. Peres, P. D. Reis, L. S. Pereira, and F. P. Salles, "Use of microturbines in remote isolated oil and gas facilities in Brazil", *IEEE Ind. Appl. Mag.*, pp. 62-68, Nov./Dec. 2008.
- [7]. M.venturini, Newsine wave in sine wave out, Conversion Technique Which Eliminates ,proceeding of powercon 7, pp.E3/1-E3/15,1980 Google (internet) Powercon 7, pp. E3/1-E3/15, 1980.
- [8]. M. Venturini, A New Sine Wave in Sine Wave out, Conversion Technique Which Eliminates Reactive Elements, proceeding of powercon7, pp.E3/1-E3/15,1980
- [9]. A. Alesina, M. Venturini, "Analysis and Design of Optimum-Amplitude Nine Switch Direct AC-AC Converter", *IEEE Trans. power electron*, vol.4.no.1.pp.101-112,jan.1989
- [10]. P.W. Wheeler, J. Rodriguez, J.C. Clare, et al., "Matrix Converters: a Technology Review", *IEEE Trans. Ind.Electron*, Vol.49,no.2,pp.276-288, April 2002 H. Karaca, R. Akkaya, "A Matrix Converter Controlled with the Optimum Amplitude-Direct Transfer Function Approach", 6th International conference on Electrical Engineering ICEENG 2008 may 2008
- [11]. D. Casadei, G. Serra and A. Tani, "Reduction of the Input Current Harmonic Content in Matrix Converters under Input /Output Unbalance" *IEEE Trans.ind.Electron*, vol.45,no.3,pp.401-409.june 1998
- [12]. S. Campbell, H. A. Toliyat, "DSP-Based Electromechanical Motion Control", *CRC Press*, pp. 307-325, 2004.
- [13]. M. E. O. Filho, E. R. Filho, K. E. B. Quindere, J. R. Gazoli, "A Simple Current Control for Matrix Converter", *IEEE-International Symposium on Industrial Electronics*, pp. 2090-2094, 2006.
- [14]. K. Sun, D. Zhou, L. Huang, K. Matsuse, "Compensation Control of Matrix Converter Fed Induction Motor Drive under Abnormal Input Voltage Conditions", *IEEE-IAS'04*, pp. 623-630, 2004.